

FABRICATION GUIDE



STUDIO

COLLECTION®

A BRAND OF ARISTECH SURFACES LLC

Questions pertaining to any procedure detailed herein should be addressed to the STUDIO Collection® Technical Services Department.

+1 (800) 428-6648

+1 (505) 864-3800

Fax +1 (505) 864-7790

This fabrication guide has been prepared to assist the fabricator and installer in the proper methods for seaming, polishing, patching and handling our Avonite Surfaces® Acrylic Solid Surface and STUDIO Collection® design resin products.

STUDIO Collection® brand, building and surfacing materials are warranted to be free from defects at time of manufacture. Any materials found defective will be replaced promptly.

Information or references to application, code compliance or specific standards are provided for convenience only. The accuracy or suitability of any recommendations in this guide must be verified by the user, Aristech Surfaces LLC disclaims any legal responsibility.

WHO WE ARE

Since 1983, the Aristech Surfaces LLC, Avonite Surfaces® and STUDIO Collection® brands have been a pioneer in solid surfacing. We have been known for our unbridled passion and spirited innovations. We have been with many of you from the beginning. For more than 30 years, we've celebrated the relationship between extraordinary product, design and craftsmanship. We are inspired by and committed to designers and fabricators with a passion for bringing forth original ideas and taking them beyond the ordinary.

HOW TO USE THIS GUIDE

We at Aristech Surfaces LLC hope you will find the following Fabrication Manual to be a useful tool. It was created to help you discover unlimited design possibilities, which will lead to wonderful solutions for you and your clients. Although many applications are covered in this guide, there will be new applications that may not be covered in detail. Our fabrication guide is designed to provide you with the fundamental knowledge of fabrication. These fundamentals can be adapted for new applications.

If you have specific questions or requests, our friendly and expert technical staff is eager to help. Feel free to call your regional representative or contact us at +1 (800) 428-6648.

Important updates such as Technical Bulletins published after the printing date of this manual are also available for download. Certified fabricators should periodically check for updates and add them to this guide. For additional copies of this guide or quick references for your clients, please visit www.aristechsurfaces.com/studiocollection, where the complete guide and individual sections are available for download.



TABLE OF CONTENTS

SECTION 1: INTRODUCTION

- 1.1 Product Introduction 4
- 1.2 Health and Safety 5
- 1.3 Storage and Handling 7
- 1.4 Color Matching 8
- 1.5 Layout 8
 - .1 Glass / Metallics 10
 - .2 Petals / Whimsy 11
 - .3 Transluscent / Veining 12
 - .4 Metallic 14

SECTION 2: FABRICATION

- 2.1 Tooling 14
- 2.2 Machining Seams 16
- 2.3 Seam Preparation 17
- 2.4 Joining 18
- 2.5 Clamping Seams 20
- 2.6 Finishing Seams 21
- 2.7 Edge Build Ups 22
- 2.8 Clamping Edges 23
- 2.9 Machining Edges 24
- 2.10 Sanding and Polishing 24
- 2.11 Sanding and Polishing "DRY CUT" 27
- 2.12 Finishing Guidelines 28
- 2.13 Designing and Fabricating Movement Colors 29

SECTION 3: INSTALLATION

- 3.1 Installation 30
- 3.2 Sinks, Bases, and Bowls 34

SECTION 4: PATCHING AND INLAY

- 4.1 Patching 37
- 4.2 Color Inlay 38
- 4.3 Catalyst Ratio Chart 39

SECTION 5: SPECIAL APPLICATIONS

- 5.1 Wall Panels and Signage 40
- 5.2 Thermoforming 40
- 5.3 Repairs 42
- 5.4 Partitions 44

SECTION 6: SUPPORT MATERIALS

- 6.1 Fabrication Support 44
- 6.2 Sanding & Polishing Accessories 46
- 6.3 Care and Maintenance 47
- 6.4 Warranty and Claims Processing 48
- 6.5 Limited Warranty Interior 50

1.1

STUDIO Collection® Product Introduction



For over 30 years the debate of polyester versus acrylic solid surface has rumbled through fabrication shops. Aristech Surfaces LLC is in the unique position of offering both types of products. These product types share many common characteristics but some STUDIO Collection® products are so unique that they deserve special recognition for their applications and fabrication techniques.

To Fill or Not to Fill

The majority of solid surface products are composed of polymer resins and a mineral filler called alumina trihydrate (ATH). The resins are typically polyester, acrylic, or a blend of the two. Polyester resin is a thermoset polymer while acrylic is a thermoplastic resin. To produce a solid surface product with acrylic resin, you must add ATH filler. Only with the filler can you create an acrylic product that can be cut, shaped and sanded. Without the filler the acrylic resin is too soft. Solid surface products made with polyester resins do not require the ATH filler to be machined. Producers, therefore, have a choice of how much ATH filler to use.

ATH filler is a fine white powder that clouds the matrix. Products with high levels of ATH are opaque whereas products using small amounts can maintain their clarity and depth. This is where the Studio Collection® stands alone. We are the only major producer of solid surface that has chosen to create some products with minimum amounts of fillers to achieve depth and clarity found in no other solid surface product.

Our STUDIO Collection® Design Resin Palette, features a wide variety of products that are unparalleled in their beauty and composition. From dynamic colors and natural textures, to our series of recycled content products and rich collections inspired by glass, concrete, and metallics, no other manufacturer offers you more choices.

Standard Sheet Size is a nominal 36" x 120" x 12mm (91.5cm x 304.8 cm x 12mm)

Custom colors are available, at low Minimum Order Quantities.

These products are made in the USA at our Belen, NM facility.

PRODUCT IDENTIFICATION:

Color ID #
8570



Our Acrylic Solid Surface products bring innovation to today's most popular colors. Our production facility allow us to produce acrylic solid surface up to 60" wide. This wide width can save you time and money by eliminating seams and reducing labor costs. These savings can be even more dramatic using our Right-Size sheet capabilities.

Visit www.aristechsurfaces.com/avonite for details.

1/2" Standard Sheet Size is 30" x 144" x 12mm (76.2cm x 365.7cm x 12mm)

1/4" Standard Sheet Sizes are:
 36" x 96" x 6mm (914mm x 2,438mm x 6mm)
 48" x 96" x 6mm (1214mm x 2,438mm x 6mm)
 60" x 96" x 6mm (1,518mm x 2,438mm x 6mm)

These products are made in the USA at our Florence, KY facility.

Shaped Products

Fully integrated sinks provide a seamless bond between the counter and sink leaving no space for bacteria to gather. This non-porous combination remains the wise choice for healthcare facilities and more.

Wet Wall Panel System

The Avonite Surfaces® Wet Wall Panel system includes our seamless wide wall panels with optional pans and accessories. The standard wall panels are available in 36", 48" and 60" widths and a full 96" high. These standard dimensions are stocked in eleven popular colors and are available in all Avonite Surfaces® Acrylic Solid Surface products. (MOQs may apply).

1.2

Health and Safety Information

FOR SHEET AND SHAPED PRODUCTS FIRST AID PROCEDURES:

STUDIO Collection® Design Resin material is non-toxic; however, during fabrication such as sawing, routing, and sanding, dust consisting of cured resin and filler is generated. This dust is classified as "Nuisance Dust".

INHALATION:

- "Nuisance Dust"— Overexposure to dust may cause irritation of the respiratory tract. Should this happen, remove the affected individual to fresh air. If symptoms persist, consult a physician.
- Styrene — Although no vapor build-up is expected, excessive inhalation of vapors can cause nasal and respiratory irritation, dizziness, weakness, fatigue, nausea, headache, and even asphyxiation. Remove the affected individual to fresh air. If symptoms persist, consult a physician.

SKIN OR EYE:

- "Nuisance Dust"— May cause irritation. Wash skin and flush eyes with water for at least 15 minutes. Contact physician if irritation persists.
- Styrene — Vapor concentration is expected to be too low to cause irritation, but odor is recognizable. Excessive exposure can cause severe eye irritation and moderate skin irritation. Wash skin and flush eyes with water for at least 15 minutes.

EXPOSURE CONTROL METHODS: Provide sufficient ventilation and dust pick-up at saw, sander, drill, or router to keep dust level below 10mg/m³ TWA (Time Weighted Average) for total dust, or provide and make mandatory the wearing of NIOSH approved fitted dust respirators.

EXPOSURE CONTROL METHODS: (cont.)

Wear protective leather or cotton gloves, safety glasses, and safety shoes when installing or fabricating Avonite Surfaces® solid surfacing material.

DISPOSAL PROCEDURES: Dust from fabrication operations is non-hazardous. Collect in impervious bags. Dispose of dust and scrap in accordance with local, state, and federal regulations. FOR MORE COMPLETE INFORMATION, **REQUEST THE (SDS) SAFETY DATA SHEET.**

INLAY RESIN**CAUTION:**

- FLAMMABLE COMPONENTS; AVOID HEAT, SPARKS AND OPEN FLAME.
- WEAR SAFETY GLASSES AND PROTECTIVE GLOVES.
- FOR PROFESSIONAL USE ONLY.
- USE ONLY AS RECOMMENDED.

The Inlay Resin is a polyester resin used with MEK peroxide. These components and vapors may cause irritation of the skin, eyes, nose, and throat. AVOID CONTACT WITH EYES, SKIN AND CLOTHING. USE ONLY WITH ADEQUATE VENTILATION; AVOID BREATHING VAPORS. WASH HANDS AFTER USE.

EMERGENCY AND FIRST AID PROCEDURES:

In case the resin or catalyst contacts your skin, wash with soap and water, for at least 15 minutes. For eyes, immediately flush with water for at least 15 minutes. Contact physician if irritation persists. In case of ingestion, immediately consult a physician or your local poison control center, identifying the catalyst as methyl ethyl ketone (MEK) peroxide solution in dimethyl phthalate containing a small amount of hydrogen peroxide, and the resin as an unsaturated polyester in styrene monomer.

SPECIAL HEALTH EFFECTS: Excessive inhalation of resin monomer may aggravate pre-existing medical conditions such as, but not limited to, chronic respiratory problems, skin disease, and central nervous disorders. There is a low health risk from inhalation of the filler dust. Avoid inhalation or eye contact.

DISPOSAL PROCEDURES: Un-reacted resin and hardener are classified as hazardous waste. All components should be disposed by mixing so that they react and become fully cured and solid. At this point, they can then be disposed in accordance with local, state, and federal regulations, as non-hazardous solid waste.

FOR MORE COMPLETE INFORMATION, REQUEST THE (SDS) SAFETY DATA SHEET, or visit www.aristechsurfaces.com/studiocollection

STUDIO Collection® SOLID SURFACE ADHESIVE

- FLAMMABLE COMPONENTS: Adhesive Component A contains acrylic resin and Component B contains benzoyl peroxide. The liquid and vapors may cause irritation to skin, eyes, nose and throat and may cause an allergic skin reaction.
- AVOID HEAT, SPARKS, AND OPEN FLAME
- USE ONLY AS DIRECTED
- WEAR SAFETY EYE PROTECTION
- AVOID CONTACT WITH EYES, SKIN, AND CLOTHING
- HAVE ADEQUATE VENTILATION AVOID BREATHING VAPORS
- WASH HANDS AFTER USE

EMERGENCY AND FIRST AID PROCEDURES:

If the Adhesive resin or hardener contacts your skin, wash with soap and water for 15 minutes. For eyes, immediately wash thoroughly with plenty of water for 15 minutes and consult a physician. In case of accidental ingestion, immediately consult a physician or your local poison control center, identifying the hardener

as benzoyl peroxide in plasticizer and the resin as acrylic resin in methylmethacrylate monomer.

SPECIAL HEALTH EFFECTS:

Excessive inhalation of resin monomer may aggravate pre-existing medical conditions such as, but not limited to, chronic respiratory problems, skin disease, and central nervous disorders and may cause nausea and loss of consciousness.

DISPOSAL PROCEDURES:

Acrylic resin and hardener when disposed in liquid state are hazardous waste but when mixed and polymerized are non-hazardous solid waste. Dispose of used or unused STUDIO Collection® Adhesive by mixing components, allowing the mixture to solidify, and then disposing in accordance with applicable local, state and federal regulations. The information and statements herein are believed to be reliable but are not to be construed as a warranty or representation for which we assume legal responsibility.

FOR MORE COMPLETE INFORMATION,
REQUEST THE (SDS)
SAFETY DATA SHEET, or visit
www.aristechsurfaces.com/studiocollection

1.3

Storage and Handling

FIGURE A

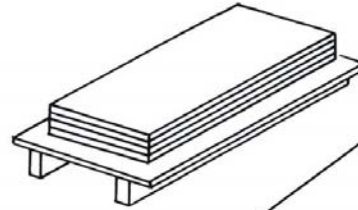
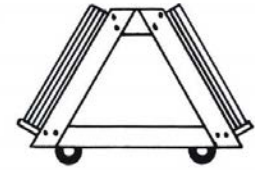
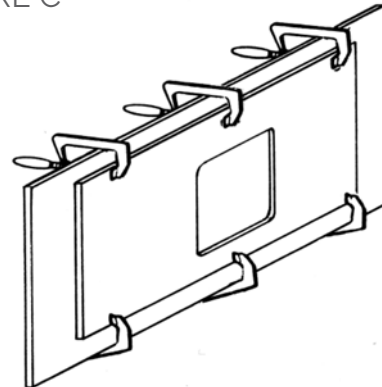

FIGURE B



STUDIO Collection® material should always be stored FLAT and evenly supported. **Figure A** demonstrates a framed substrate. **Figure B** is an A-Frame storage bin. Material must be stored under roof that provides protection from exposure to direct sunlight and precipitation (rain, snow, etc.). Material should not be exposed to extreme temperature changes (>20° F in one hour).

FIGURE C



Always carry sheets upright in a vertical position. To avoid chipping and scuffing, do not drop or drag sheets. Fabricated sections with angles or seams should be handled carefully with support at the angled or seamed area. A carrying board should be used for tops with cut outs (**Figure C**).

FIGURE D

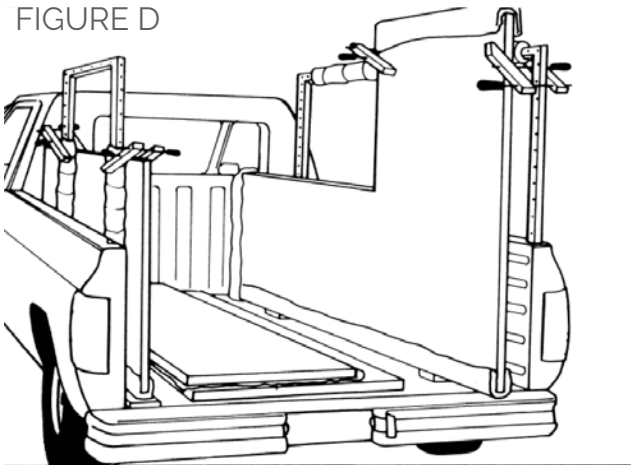

STUDIO Collection® can be transported lying flat on an evenly supported and padded surface. Large fabricated sections should be transported on edge. Pad the edges to prevent damage and brace to prevent movement (Figure D). When transporting Avonite® sheets in an exposed vehicle, pieces should be wrapped to prevent damage from extreme temperature changes. Avoid exposing fabricated pieces to direct sunlight. Uneven solar heating will cause distortion of fabricated parts. Allow pieces to cool to room temperature at the job site prior to installation.

1.4

Color Matching

Every STUDIO Collection® sheet has a label which displays an identification number. When ordering multiple sheets to be seamed, be sure that sheets come from the same batch.

Please notify the distributor of this fact when ordering. Advise that you need sheets with consecutive numbers. Although STUDIO Collection® sheets have been inspected prior to shipment, always remove the peel coat and inspect for color consistency, surface blemishes, warping, and dimensional consistency.

Remove the protective peel coat and arrange the sheets in the manner in which they will be installed. Sand 12"-16" (305mm - 407mm) of the surface to verify color match. After sanding, wet the material with alcohol or water.

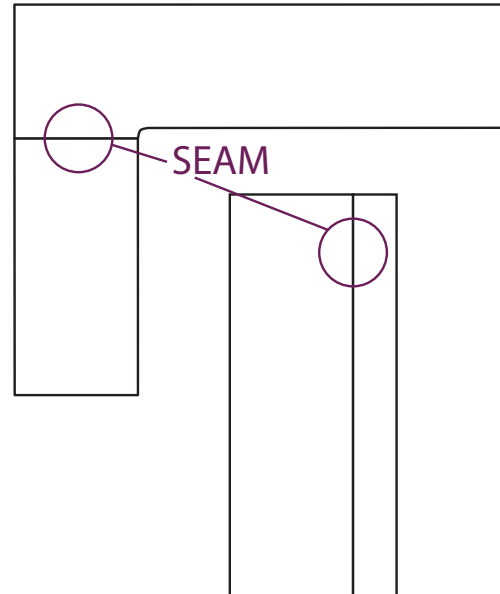

1.5

Layout

THE L - TEMPLATE

The L-Template is a convenient way to fabricate the L or U shaped counter top. The L-Template should be 10' (305cm) long by about 30" (76cm) wide. The inside corner will have a minimum 1" (25.4mm) radius. The L-Template may be reversed and used for either side. Clamp the L-Template securely to the STUDIO Collection® material. Place some registration marks on the backside and end of the template. Use a 3 HP router and template guide for cutting. After cutting, turn the material bottom side up to bond on the drop edge and inside corner build up. When the STUDIO Collection® Adhesive has cured, turn the material face up and re-clamp the L-Template. Using the registration marks, place the template far enough back to remove the excess material and STUDIO Collection® Design Resin Adhesive. This will result in a clean and smooth edge requiring minimal sanding.

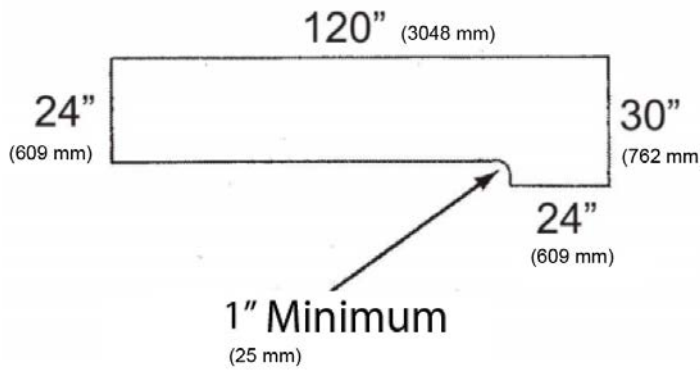

LOCATING SEAMS

When you lay out your job, consider where you need to place the seams. Make as many seams as possible in the shop and not in the field. All seams must be supported. Avoid placing seams in the following locations:

1. Inside corners minimum 1" (25 mm)
2. In cut outs
3. Over dishwashers or other heat producing appliances
4. When using dark colors, avoid placing seams in direct sunlight

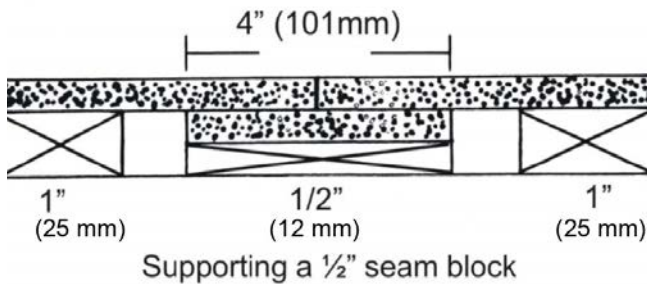

SEAM BLOCKS

The use of seam blocks is recommended for all seams. Seam blocks should be 4" (101mm) wide and at least 1/2" (12mm) thick. Join the seam block to the underside using STUDIO Collection® Design Resin Adhesive. Spread the adhesive over the entire surface so there are no voids. The seam block should cover the entire length of the seam.

Seam blocks are highly recommended. Seams are not covered under warranty. The seam block provides you with the strongest seam possible.

STUDIO Collection® Glass, Frosted Glass and Petals Series products require different seam block methods. (See section 1.8.)

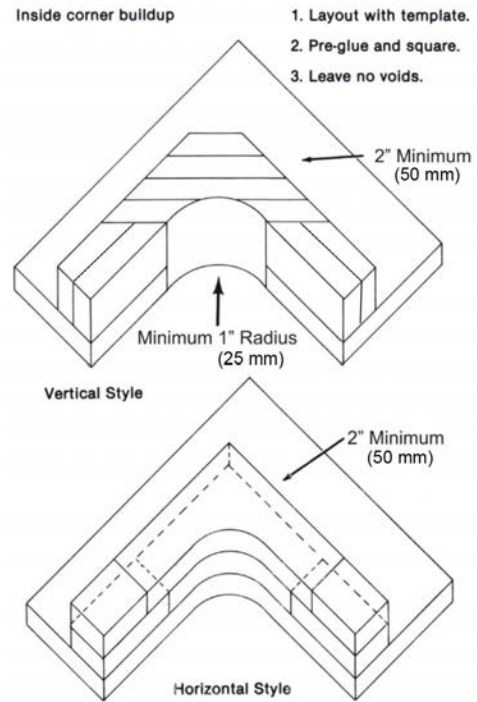

INSIDE BLOCKS

STUDIO Collection® Design Resin material requires a minimum 1"radius on drop edge inside corners. This diagram shows the recommended build-up. After the build-up is made, use a template to cut the desired radius (see L-Template).

EXPANSION AND CONTRACTION

Like all solid surface materials, STUDIO Collection® material expands or contracts with temperature variation. The following changes in length may occur with a swing in temperature of 55° F (31° C).

Class I (Filled)—1/8" (3mm) for every 10' (304.8cm)

Class III (Unfilled)—3/16" (5mm) for every 10' (304.8cm) Always leave appropriate clearances for expansion and contraction.

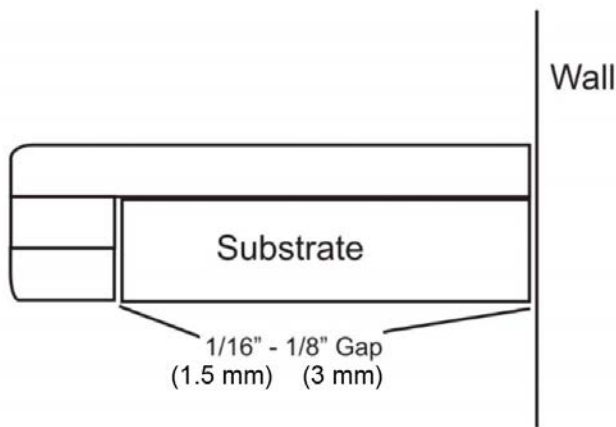

Section Drawing "Counter Top"

TILE BACKSPLASHES

The transition from tile to STUDIO Collection® should be silicone sealed and not grouted.

TRANSLUCENT COLORS

Glass, Frosted Glass, Petals and Whimsy Series products are translucent and may require a seal coat of water based interior/exterior primer on the back of the sheet to reduce shadowing effects. For more information call the Technical Services Department +1 (800) 428-6648.

1.5.1

Layout Glass/Metallics

DESIGNING AND FABRICATING WITH STUDIO Collection® GLASS SERIES AND SOME METALLICS SERIES

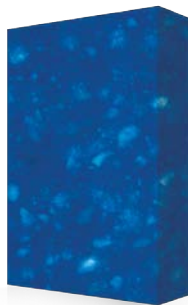

Glass Series

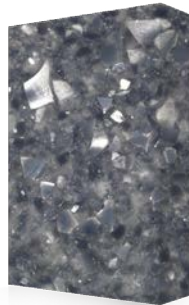

Pearl Series

The STUDIO Collection® Glass product allows you to exercise a great deal of creativity. For this reason, it is expected that there will be many new applications that will produce unanticipated effects. By all means experiment, be creative, and consult with us as you have questions. However, always make sure that the end result will meet your expectations as well as those of your customer. Due to their translucency, Silver Pearl, Charcoal Pearl, and Celestial Pearl should be fabricated in the same manner as the Glass and Petal Colors. Customer test samples are encouraged to ensure the final product will meet expectations.

THE NATURE OF THE STUDIO Collection® GLASS SERIES

Keep in mind that in horizontal applications dabs of silicone, supports, and under-mount sink flanges will show through these products like any typical glass product. When these products are laminated together for a thicker appearance, such as with a stacked or drop edge, they will appear darker due to the reduced light transmission. Alternative edges may also need to be tested to observe their effect. The thicker material will have an effect on the color observed. These special effects can be worked into the design for a unique aesthetic.

BACKLIT APPLICATIONS

For backlit applications we recommend using ½" (12mm) acrylic to support larger spans. Frost or white acrylic may also be used to diffuse the light source. When adhering the STUDIO Collection® translucent product to the acrylic, we recommend small pieces of 3M VHB double sided tape. If clear acrylic is used, it should be sanded with 100 Micron to frost the surfaces to aid adhesion of the tape.

Glass products offer unique opportunities with backlighting or painting the back different colors to achieve custom hues that transmit through the sheet. In some cases, apparent

sheet color will be influenced by the lighting source, whether backlit or room lighting. Always check bulb temperature to be sure it is in the daylight range of 5,000 – 5,500K. Many common LED lights are in the 2,750-3,500K range which emits a predominantly yellow/orange spectrum, equivalent to warm white incandescent lighting. Seam quality is crucial as seams may be more visible backlit than in normal room lighting. Seams should be minimized where possible. Backlit applications that require deck seams or have unsupported spans require special consideration. Always perform inspections and quality checks with the desired room lighting and backlighting levels to confirm the desired end result.

When Glass products are chosen for more typical applications, where less transparency is desired, the backside of the finished sheet must be undercoated to hide any supports. For the best results, we recommend undercoating the sheet with INSL-X Stix waterborne Primer or Sherwin Williams DTM Bonding Primer. This brightens the top closer to the sample chip but magnifies the contrast to the darker edge. This effect should be demonstrated to the end user.

SEAM BLOCKS

For best results, prepare seams with the Wavy Bit. Once the seam is complete, turn the sheet over for the remaining fabrication. Clean the excess glue where the 4" seam block will be applied. Paint the back side with the adhesion primer. Two coats are recommended. Allow to dry completely.

The seam block must run the full length of the seam. Apply a generous amount of adhesive to the seam block and the edge that meets the back of the buildup edge. Uniform weight should be placed on the seam block to assure even pressure as the adhesive is drying. Seam blocks will be visible in backlit applications and will appear as shadows. Placing seams where supports are required will minimize their effects.

Please call Technical Services at 800.428.6648 if you have questions.

1.5.2

Layout Petals/Whimsy

DESIGNING AND FABRICATING WITH STUDIO Collection® PETALS and WHIMSY SERIES



Petals Series



Whimsy Series

The STUDIO Collection® Petals product allows you to exercise a great deal of creativity. For this reason, it is expected there will be many new applications that will produce unanticipated effects. By all means experiment, be creative, and consult with us as you have questions. However, always make sure the end result will meet your expectations as well as those of your customer. Test samples are encouraged to ensure the final product will meet expectations.

THE NATURE OF THE STUDIO Collection® PETALS SERIES

Keep in mind in horizontal applications dabs of silicone, supports, and under-mount sink flanges will show through these products like any typical glass product. When these products are laminated together for a thicker appearance, such as with a stacked or drop edge, they will appear darker due to the reduced light transmission. Alternative edges may also need to be tested to observe their effect. The thicker material will have an effect on the color observed. These special effects can be worked into the design for a unique aesthetic.

SEAMING PETALS

The Petals product should be fabricated the same way as the original Glass Series. Because of the very large petal shapes, these products will have more conspicuous seams. The Petal products are hand crafted creating organic patterns that have different petal flake concentrations across the sheet. This too will affect the appearance of seams in a complete top.

BACKLIT APPLICATIONS

For backlit applications, we recommend using ½" (12mm) acrylic to support larger spans. Frost or white acrylic may also be used to diffuse the light source. When adhering the Studio Collection® Translucent product to the acrylic, we recommend small pieces of 3M VHB double sided tape. If clear acrylic is used, it should be sanded with 100 Micron to frost the surfaces to aide adhesion of the tape.

Petal sheets offer unique opportunities with back lighting or painting the back different colors to achieve custom hues that transmit through the sheet. In some cases, apparent sheet color will be influenced by the lighting source, whether back lit or room lighting. Always check bulb temperature to be sure it is in the daylight range of 5,000 – 5,500K. Many common LED lights are in the 2,750-3,500K range which emits a predominantly yellow/orange spectrum, equivalent to warm white incandescent lighting. Seam quality is crucial as seams may be more visible backlit than in normal room lighting. Seams should be minimized where possible. Backlit applications that require deck seams or have unsupported spans require special consideration. Always perform inspections and quality checks with the desired room lighting and backlighting levels to confirm the desired end result.

When petal products are chosen for more typical applications, where less transparency is desired, the backside of the finished sheet

must be undercoated to hide any supports. For the best results, we recommend undercoating the sheet with INSL-X Stix waterborne Primer or Sherwin Williams DTM Bonding Primer. This brightens the top closer to the sample chip but magnifies the contrast to the darker edge. This effect should be demonstrated to the end user.

SEAM BLOCKS

For best results, prepare seams with the Wavy Bit. Once the seam is complete, turn the sheet over for the remaining fabrication. Clean the excess glue where the 4" seam block will be applied. Paint the back side with the adhesion primer. Two coats are recommended. Allow to dry completely. The seam block must run the full length of the seam. Apply a generous amount of adhesive to the seam block and the edge that meets the back of the buildup edge. Uniform weight should be placed on the seam block to assure even pressure as the adhesive is drying. Seam blocks will be visible in backlit applications and will appear as shadows. Placing seams where supports are required will minimize their effects.

Please call Technical Services at 800.428.6648 if you have questions.

1.5.3

Layout Translucent/Veining



Translucent Series



Translucent
Veined Series

DESIGNING AND FABRICATING WITH STUDIO Collection® TRANSLUCENT AND TRANSLUCENT VEINING SERIES

The new STUDIO Collection® Translucent products allow you to exercise a great deal of creativity. For this reason, it is expected that there will be many new applications that will produce unanticipated effects. By all means experiment, be creative, and consult with us as you have questions. However, always make sure the end result will meet your expectations as well as those of your customer. Test samples are encouraged to ensure the final product will meet expectations.

THE NATURE OF THE STUDIO Collection® TRANSLUCENT SERIES

STUDIO Collection® recommends that the translucent products be used in vertical applications; however, keep in mind that in horizontal applications, dabs of silicone, supports, and under-mount sink flanges will show through these products like any typical glass product. When these products are laminated together for a thicker appearance, such as with a stacked or drop edge, they will appear darker due to the reduced light transmission. Alternative edges may also need to be tested to observe their effect. The thicker material will have an effect on the color observed. These special effects can be worked into the design for a unique aesthetic.

BACKLIT APPLICATIONS

For backlit applications we recommend using ½" (12mm) acrylic to support larger spans. Frost or white acrylic may also be used to diffuse the light source. When adhering the STUDIO Collection® Translucent product to the acrylic, we recommend small pieces of 3M VHB double sided tape. If clear acrylic is used, it should be sanded with 100 Micron to frost the surfaces to aide adhesion of the tape.

Translucent sheets offer unique opportunities with back lighting or painting the back different colors to achieve custom hues that transmit through the sheet. In some cases, apparent

sheet color will be influenced by the lighting source, whether back lit or room lighting. Always check bulb temperature to be sure it is in the daylight range of 5,000 – 5,500K. Many common LED lights are in the 2,750-3,500K range which emits a predominantly yellow/orange spectrum, equivalent to warm white incandescent lighting. Seam quality is crucial as seams may be more visible backlit than in normal room lighting. Seams should be minimized where possible. Backlit applications that require deck seams or have unsupported spans require special consideration. Always perform inspections and quality checks with the desired room lighting and back lighting levels to confirm the desired end result.

When translucent products are chosen for more typical applications, where less transparency is desired, the backside of the finished sheet must be undercoated to hide any supports. For the best results, we recommend undercoating the sheet with INSL-X Stix waterborne Primer or Sherwin Williams DTM Bonding Primer. This brightens the top closer to the sample chip but magnifies the contrast to the darker edge. This effect should be demonstrated to the end user.

SEAM BLOCKS

For best results, prepare seams with the Wavy Bit. Once the seam is complete, turn the sheet over for the remaining fabrication. Clean the excess glue where the 4" seam block will be applied. Paint the back side with the adhesion primer. Two coats are recommended. Allow to dry completely. The seam block must run the full length of the seam. Apply a generous amount of adhesive to the seam block and the edge that meets the back of the buildup edge. Uniform weight should be placed on the seam block to assure even pressure as the adhesive is drying. Seam blocks will be visible in backlit applications and will appear darker or as shadows. Placing seams where supports are required will minimize their effects.

SEAMING THE NEW TRANSLUCENT VEINING SERIES

Because of the veining, these products will have a more conspicuous seam. To minimize this, seam with the vein. In larger L shape counter tops we recommend a 2" offset miter.

Please call Technical Services at 800.428.6648 if you have questions.

1.5.4

Layout Metallics

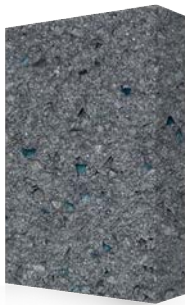

DESIGNING AND FABRICATING WITH METALLICS

The appearance and seaming qualities of our STUDIO Collection® metallic colors is different than conventional solid surfaces. These products have a light reflective quality that provides an optical effect or "direction" that shows lighter or darker depending on the angle from which they are viewed. This unique reflective quality allows patterns to be created where sheets are joined together. All seams will show this inherent reflective quality and will be visible unlike standard solid surface. The color will appear to change when viewed from different angles. These effects can be incorporated into your designs.

These directional patterns are not detectable in single sheet applications where no seam is required. Seams made from the same sheet will also be noticeable. Because of these conditions there will be no claims allowed for color matching of these products.

Designers and fabricators must consider these characteristics when using these three products.

Contact Technical Service for any questions +1 (800) 428-6648.

2.1

Tooling

STUDIO Collection® material can be easily machined with ordinary woodworking tools, such as routers, saws, planers, lathes, drills, and sanders. All blades and bits should be carbide tipped.

ROUTERS

For general purpose routing, a 1-1/2 to 2 HP router may be used. For heavier cutting of thick edges and cut outs, a 3 HP router is recommended. A 1/2" (12.7mm) shank carbide bit is needed to minimize chatter for all routing with the exception of small details like a 1/4" (6.3mm) round over or a pin stripe inlay. STUDIO Collection® material should be properly supported during all phases of fabrication.



CUT OUTS AND CURVED CUTS

A template and a router is mandatory for all cuts. The use of a saber saw will leave a rough edge where stress cracks can occur. Use a template for all inside and outside corner radiuses.

Helpful Tip

Two square feet of color matched material should be left on the job site for future repairs. Material should be placed under a bottom drawer or mounted to the inside of the sink cabinet. Mark the material to identify it is for potential repairs.

TABLE SAWS

A table saw with a minimum 2 HP motor can be used to cut STUDIO Collection® materials. The sheets should be cut face up. A good quality rip fence is necessary for accuracy. A triple chip bevel saw blade is needed for a clean cut with minimum chipping. A 10" (254mm) diameter blade should have 40 teeth with a 20° positive hook. Raise the blade 1-1/4" (32mm) above the surface of the material for the best results.



Triple Chip Bevel

TOOLING SUPPLIERS:

Forrest Manufacturing

www.forrestblades.com

1-800-733-7111

Specialtytools.com

1307 Oak Ridge Farm Hwy

Mooreville, NC 28115

800-669-5519

904-880-4944

The Pinske Edge

119 Main Street, PO Box 68

Plato, MN 55370 USA

800-874-6753

320-238-2196

FESTOOL Products

www.Festoolproducts.com

247 Mahopac Avenue,

Yorktown Heights, NY 10598

877-866-5688

Fred M. Velepec Co. Inc.

www.velepectools.com

71-72 70th Str.

Glendale, NY 11385

800-365-6636

Monument Tool Works

28 Mill St,

Assonet, MA 02702

508-644-2400



RADIAL ARM AND MITER BOX

A triple chip bevel saw blade should be used for clean cuts. These saws require a 10" (254mm) diameter blade with 60 teeth and a 5° positive hook.

2.2

Machining Seams



Use a good quality 1-1/2 – 2 HP router. Refit base with square base. Two dimensions on base allow you to turn base and remove an additional 1/16" (1.5mm). Always use a 1/2" (12.7mm) double fluted carbide router bit.



Set the router flat against straight edge. Move router with even feed speed. Allow router sound to indicate the rate of feed.



After routing edges, dry fit to assure a flat, true edge. In the dry fit process, the seam should virtually disappear. If the seam is not done correctly, redo by taking off an additional 1/16" (1.5mm). Check by dry-fitting again.



After routing, check again for a quality dry fit. Only after you have achieved a good dry fit should you proceed.

2.3

Seam Preparation

MIRROR CUTTING

Mirror cutting is a method of machining seams which cuts both edges to be seamed at the same time. Use only a 1/2" (12.7mm) shank double fluted bit. Place the two pieces to be seamed 1/4" (6.3mm) apart and secure them firmly to prevent movement. Clamp your straight edge to one side. The router must be fed through with a continuous movement without stopping. The two pieces will fit together exactly.



With 100 grit sand paper on a hardwood block, lightly score the edges to be seamed together. This step aids the adhesion between the two surfaces. Make one or two passes only. Be careful not to sand the top edge.

Seaming Table for Mirror Cutting

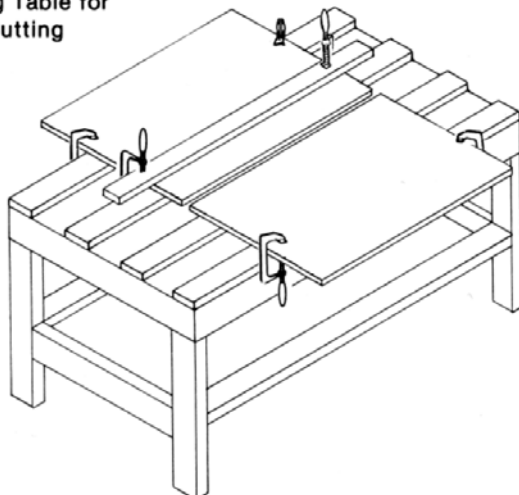

WAVY BIT SYSTEM

Another way to machine seams is to use the Wavy Edge Router Base and Bit to make two interlocking surfaces that fit snugly together. The seam edges align perfectly and do not slip, and a wavy surface seam is stronger because it has more adhesive area allowing better bonding. Here's how: rout one seam edge with one side of the stepped Router Base, then rotate the router 180 degrees and rout the other seaming surface. Use a high-grade carbide bit with a reversible insert blade to cut the wavy seam. Inserts eliminate re-sharpening and ensure the accuracy of every cut. You save time preparing the seams, and the automatic alignment means you will not do as much sanding to get a professional finish.



2.4

Joining

STUDIO Collection® Adhesive

Our adhesive is a pre-tinted two part adhesive and cures in approximately 40 minutes and is available in 250 ml. cartridges. The adhesive is available in several colors and clear for excellent color matches. It is specially formulated to offer superior bond strength for all STUDIO Collection® products.



CARTRIDGES

Each cartridge contains 250 ml (10 oz.) of adhesive and will adhere 35 to 45 feet (12.1M) of 1/2" (12.7mm) seam. The adhesive flows through a static mixer tube and is ready for use. Two mixer tubes are included with each cartridge. To assure positive flow of activator, dispense a small quantity of adhesive before installing mixer tube. 50ml sizes are also available for European locations.

**REFER TO MACHINING SEAMS SECTION
BEFORE APPLYING ADHESIVE**

ADHESIVE STORAGE

It is recommended that the adhesive be stored in a refrigerator for extended life. The adhesive should be acclimated to at least 60°F or 15°C before being used. Store cartridges in an upright position as shown in photo. Storage at temperatures above 75°F or 24°C may affect the shelf life, and could adversely affect proper curing of the adhesive. All cartridges are dated with an expiration date. Do not use expired adhesive.

FINAL PREP

After the dry fit is complete and you are ready to join the seam, clean edges thoroughly with isopropyl alcohol. Have seam blocks in place.



Scoring the top of the surface strengthens the bond of the excess adhesive. This helps prevent the critical top layer of the seam from pulling out when machined.

FABRICATION TIP

From time to time the bead of adhesive dispensed with the Avonite Surfaces® Solid Surface Adhesive cartridge will not contain the prescribed amount of hardener. This may arise for a variety of reasons, but the end result is that small sections of the seam may not set up as rapidly as others. There are techniques that will reduce the variation in setup time. Once the bead

of adhesive has been dispensed, a popsicle stick applicator may be used to spread the adhesive over the bonding surface. This serves to more uniformly blend the adhesive with the hardener and prevents variation in the curing time of the adhesive. Another helpful technique used frequently is to dispense two thin beads as opposed to one thick bead. This method overlaps any possible gap in the hardener and prevents uneven hardening.

DISPENSING OPTIONS

Avonite adhesive cartridges are designed to fit only in a 10 to 1 ratio system. Our systems are available in both manual and pneumatic styles. Unique Properties

- The activator is opaque and viscous, much like a paste.
- The resin is similar to the viscosity of honey.
- The "clear" Adhesive is "foggy" in appearance rather than "water clear."

For a complete list of current adhesive colors, please see Tables A.2 and A.3 in this manual, or visit www.aristechsurfaces.com/studiocollection

FABRICATION TIP

When a small amount is needed there is no reason to waste a mixing tube. Simply remove the end plug and squeeze the adhesive into a paper cup and stir for one minute.



2.5

Clamping Seams

CLAMPING METHODS

Before clamping seams, be sure to double check the following:

1. Surfaces to be bonded are properly scuffed with 100 grit sandpaper.
2. Separation paper is in place.
3. Pieces are properly aligned and level.
4. Edges are clean.

Prepare some reusable glue blocks made from scrap pieces of STUDIO Collection® material. They should be 1"(25.4mm) thick by 1-1/2" (38mm) w x 2" (51mm). Bevel the edges and drill 1/4" (6.3mm) holes as shown in Figure A so the isopropyl alcohol will penetrate and release the hot melt bond when it is time to remove them.

On a standard countertop, hot melt 3 pairs of blocks about 6"(152mm) apart across the seam area. Bar clamps are then used to bring the joint together. Be sure the glue squeezes out to ensure a tight seam. However, avoid using excessive pressure which may cause too much glue to be squeezed out resulting in a weak joint.



After the adhesive has cured, remove the blocks by applying isopropyl alcohol and allowing a few moments for the hot melt to soften. Also apply alcohol in the 1/4" (6.3mm) holes to allow for penetration of alcohol in the center of the block. Then place a chisel under the beveled edge of the block and gently pry; do not use excessive force. If the block does not free immediately, apply more alcohol and allow to soak for a while longer.

Other effective clamping methods use the Pinske Power Grips with brackets and turnbuckle, as shown in below.



or the Paralign Clamps shown on page 21. (Available through Monument Toolworks).

Other innovative devices designed by independent suppliers may save time or simplify difficult tasks. If there is any question regarding the use of such devices, please contact STUDIO Collection® Technical Services at +1 (800) 428-6648.



SANDING SEAMS

The following procedure will efficiently finish seam areas. For illustration, please refer to the below

2.6 Finishing Seams

REMOVING THE FLASH LINE

Do not attempt to sand away the flash line with a belt sander. Instead, attach two skis to the base of a router. Use a flat bottom cutting bit and lower the cutter to just over the surface of the sheet. Cutting the flash line off this way eliminates sanding time.

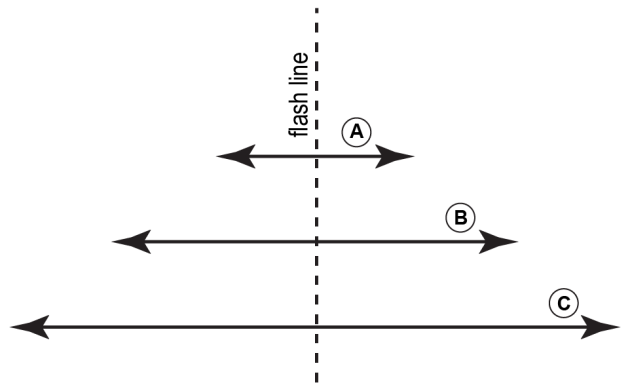

1. Trim the STUDIO Collection® Design Resin Adhesive flash line with router on skis or offset trim router.
2. The remainder of the flash line should first be sanded with 100 micron paper. It is important that sanding extend on either side of the seam, without concentrating directly on the seam, as illustrated by Point A. The 100 micron sanding should extend to about 6" (152mm) on either side of the flash line. Concentrated sanding could cause a valley, or dip, in the seam area.
3. The next step is to sand with 80 micron paper. The sanding area now extends to about 12" (305mm) on either side of the flash line, as shown in Point B.
4. Once the seam is sanded level, continue the standard finishing procedure by feathering out the finish in the seam area to blend with the final finish of the top, as shown in Point C.

2.7

Edge Build-Ups

GENERAL REQUIREMENTS

The construction of your edge build up is determined by the profile you wish to achieve. Strips are laminated together to acquire the bulk for the design. Confirm that your construction provides a minimum 1/2" (12.7mm) of bonding surface area after the profile is cut. Larger bonding surfaces create stronger edges. The diagrams below demonstrate construction methods referred to as Stacked Edges and Drop Edges. In general, Stacked Edges provide the greatest bonding surface area and therefore are the preferred method. Stacked Edges also allow layers to be put on one at a time. This ensures tighter joints and to offset the build ups at inside corners. Sand all surfaces to be glued with 100 grit paper sanding block to enhance the bond. **It is highly recommended that all edges have a minimum 1" (25.4mm) bonding surface.**

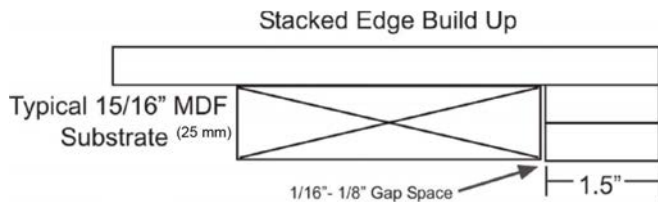

Stacked Edges: laminate strips together for the desired thickness. SAND BOTH SIDES of the strips with 100 grit. Laminate strips face to back.

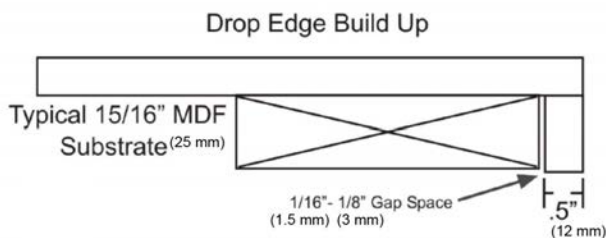

Drop Edges: use a single strip turned vertically on edge. This is a common method but is

the weakest construction method due to the minimum bonding surface area. This method is also limited to small round over or beveled profiles. Additional strips can be used to increase bulk and strength. A rabbet joint can be useful for hiding seams with colors that contain patterns when utilizing a dropped edge.

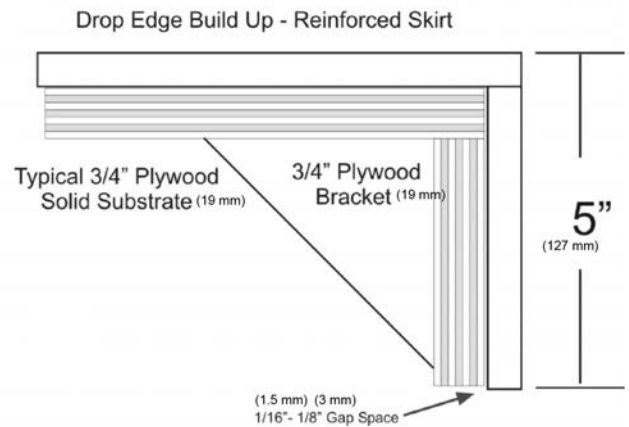

Any drop edges greater than 1-1/2" (38mm) tall require reinforcement. The above shows a typical skirted front vanity. Note that the skirt is reinforced by plywood. The plywood substrate is also reinforced with brackets to prevent damage.

For added reinforcement we recommend gluing a 1/2" (12.7mm) x 1/2" (12.7mm) slice of solid surface behind the skirt edge joint.

V-Grooving edges is another form of drop edge. Although the bonding surface is somewhat increased, any v-groove edges over 1-1/2" (38mm) tall should be reinforced.

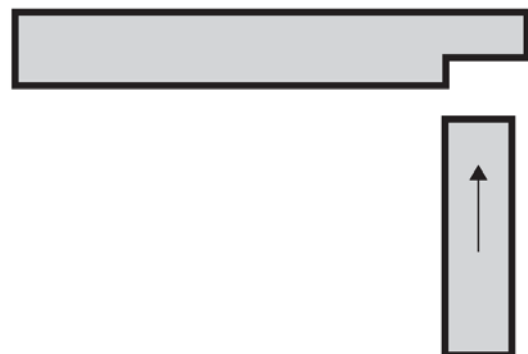

Rabbet Joint, shown above.

2.8

Clamping Edges

LAMINATING BUILD-UP DIRECTLY ON COUNTERTOPS

Edges should be straight and free of chatter-marks. Clean bottom of sheet and fascias with isopropyl alcohol. Light block sanding may be needed where edge is to be applied.



Dry fit and mark where they go with arrows. Hot melt some guide blocks along the backside of the edge.

Glue and clamp one edge build up at a time to prevent glue from setting up before build up strips are applied.

Apply two small beads of adhesive to the surface.

Place the drop edge in the glue and make sure an even flash line develops.

Hold the drop edge back 1/8" (3mm) to avoid any chip out on seamed edge.

Place spring clamps 2" (51mm) to 3" (76mm) apart.

Keep clamps straight to avoid tilting the drop edge back. The tips of the clamps should be in the center of the drop edge.

After the adhesive has cured, clamps may be removed. The edge can now be routed to your final configuration.



2.9

Machining Edges

LISTEN TO YOUR TOOLS

By using a high quality router and reasonable feed speed, detailed cuts can be easily achieved. Keep the router steady and make a smooth pass without stressing the motor as this can cause chatter and more labor time. Heavier cuts, such as those for a 3" (76mm) bull nose can be produced by laminating several pieces together and machining in two steps.

For Best Results...

Use a 1/2" (12.7mm) shank profile cutter. Sharp cutters require less sanding.

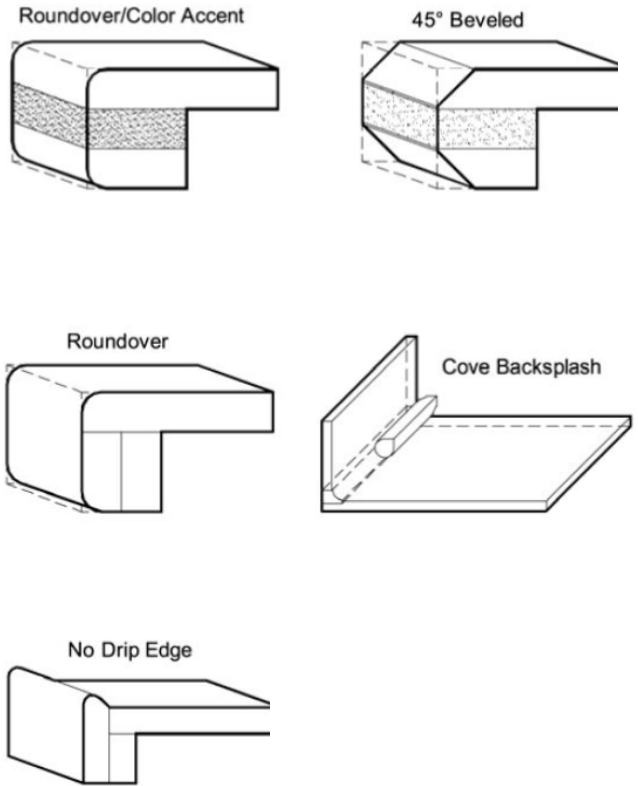

COMMON CONSTRUCTION METHODS FOR POPULAR EDGE PROFILES

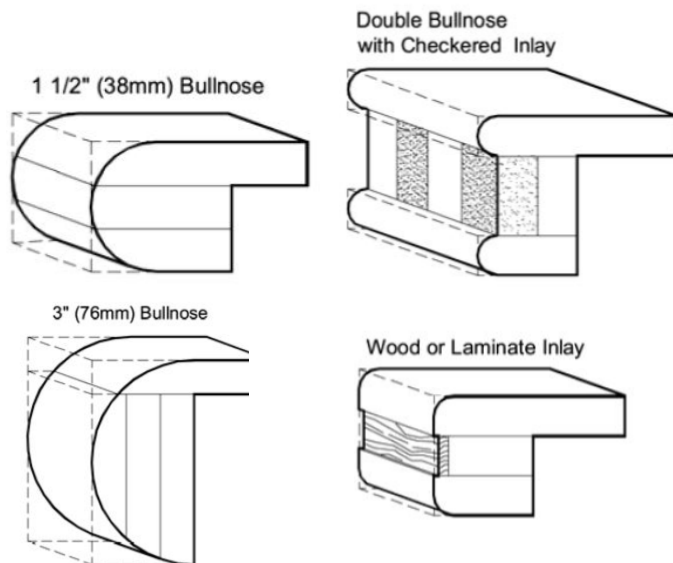

2.10 Sanding and Polishing

FINISHING

The final finish of your application must be specified and understood by the end user. Most customers choose the Satin or Polished finish.

All STUDIO Collection® sheets come from the factory with minor linear sanding lines. These lines are 60 micron or a 280 grit finish on the face. To obtain any of the possible finishes these sanding lines must be removed. This is accomplished by starting the sanding process with 60 micron.

Using a 6" (152mm) or 8" (203mm) random orbital sander will reduce your sanding time by HALF over conventional vibrating sanders and will achieve a more uniform finish. Whenever possible, use a sander with a vacuum attached (especially if the tops are polished) to minimize grinding dust back into the top.

Sanding Process

1. Move the sander in a back and forth direction.
2. Overlap each pass by 50%.
3. Sand at a slow and even pace, approximately 1" (25.4mm) per second.
4. Keep micron paper clean from sanding dust. This is easily done by putting the sanding pad on a piece of carpet while running and hold it down for a few seconds (check paper frequently).



**Each sheet of micron paper will sand 10 sq. ft (about 1 sq. M) of STUDIO Collection® material.*

Sanding Progression Table - Light Colors

Matte			Satin			Polished		
Micron (Dry)	P-Grade (Dry)	Trizact™ (Wet)	Micron (Dry)	P-Grade (Dry)	Trizact™ (Damp)	Micron (Dry)	P-Grade (Dry)	Trizact™ (Wet)
100 *	P150*	100 (dry)*	100 *	P150*	100 (dry)*	100 *	P150*	100 (dry)*
60	P240	268XA A35 (Green) (Damp)	60	P240	268XA A35 (Green) (Damp)	60	P240	268XA A35 (Green) (Damp)
Scotch-Brite™ 7447 (maroon)			30	P400	268XA A10 (Blue) (Damp)	30	P400	268XA A10 (Blue) (Damp)
			Scotch-Brite™ 7448 (gray)			Brown Sattex		268XA A5 (Orange) (Damp)
						Blue Sattex		
					Finesse-It Finishing Material	568XA CeO (White) (Damp)		

*Initial grit only required if scratches need to be removed

Use only one class of abrasive media for the entire finishing process. Do not mix media as the abrasives at each step are not always equivalent.

Sanding Progression Table - Dark Colors

Matte			Satin			Polished		
Micron (Dry)	P-Grade (Dry)	Trizact™ (Wet)	Micron (Dry)	P-Grade (Dry)	Trizact™ (Damp)	Micron (Dry)	P-Grade (Dry)	Trizact™ (Wet)
100 *	P150*	100 (dry)*	100 *	P100*	100 (dry)*	100 *	P150*	100 (dry)*
60	P240	268XA A35 (Green) (Damp)	60	P240	268XA A35 (Green) (Damp)	60	P240	268XA A35 (Green) (Damp)
Scotch-Brite™ 7447 (maroon)			30	P400	268XA A10 (Blue) (Damp)	30	P400	268XA A10 (Blue) (Damp)
			Scotch-Brite™ 7448 (gray)			Brown Sattex		268XA A5 (Orange) (Damp)
						Blue Sattex		
						Finesse-It Finishing Material		568XA CeO (White) (Damp)

*Initial grit only required if scratches need to be removed

Use only one class of abrasive media for the entire finishing process. Do not mix media as the abrasives at each step are not always equivalent.

Matte Finish

After removing the linear sanding lines with 60 micron paper, place a Scotch-Brite® pad, (#7447 Red) under the sanding pad to even out the finish. The matte finish is easily maintained and is usually the most suitable for lighter colors. Make sure the customer understands the required maintenance for the finish they have chosen. Most solid surface samples are Satin finished and likely will be what the customer is expecting.

Satin Finish

Sand with 60 micron paper, repeat sanding process with 30 micron paper. Place Scotch-Brite® pad (#7448 light gray) under sanding pad. Sand with Scotch-Brite® #7448 and soapy water. Homeowners may maintain this finish using a white Scotch-Brite® and Soft-Scrub.®

Polished Finish

After sanding with 60 micron paper, repeat the sanding process with 30 micron paper. Whenever possible, use a vacuum attached to the sander to minimize sanding dust back into the surface top. Dark colors with a high gloss finish show wear very quickly. A dark color is

not recommended for heavy use areas.

Finishing Guidelines

You should become familiar with the different colors and options you present to your clients. Most customers are expecting the gloss level they have on the sample they are choosing from. Download and print our Finishing Guidelines document. Go over these guidelines with your customers to help manage expectations.



The buffer should be variable speed between 1000-3000 RPM. Best results are achieved at lower speeds.



2.11 Sanding and Polishing *DRY CUT

POLISHING WITH THE STUDIO Collection® DRY-CUT SYSTEM

Another effective polishing method involves the use of the STUDIO Collection® Dry-Cut Finishing System abrasive bars. This is a three step system that quickly and easily removes sanding scratches. Since the compound is a solid it can be cleaner to use than 3M Marine Paste. Apply sparingly to the buffing wheel and it stays there to efficiently create a high luster finish.



Step 1: (Brown Bar)

The first step in polishing with the STUDIO Collection® Dry-Cut Finishing System is to use the brown bar (SM4036-A) with a 3M Super Duty 2+2 pad (white). Start with the STUDIO Collection® material sanded to a 30-micron finish. The brown bar must be applied directly to the buffing pad. With the buffing pad turned up and buffer running, press the bar firmly against the pad allowing it to buildup on the pad. Begin buffing the material, and be sure to apply enough pressure to deflect the pad as shown on page 2.14. Add material to the buffing pad if you feel you need more to ensure you do not build up excessive heat by using a dry pad. Repeat Step 1 as necessary to remove all of the 30-micron swirls.

Step 2: (Blue Stick)

This step will remove any marks left by the more aggressive cutting brown bar. Reverse the white pad and apply the blue stick compound (SM4036-B) to the pad. The blue stick must be applied directly to the buffing pad. With the buffing pad turned up and buffer running, press the stick firmly against the pad allowing it to build up on the pad. Add material to the buffing pad as you feel is needed to ensure you do not build up excessive heat by using a dry pad. Repeat Step 2 as necessary until you have removed the buffing swirls resulting from Step 1. To achieve a high gloss finish, complete Step 3.

Step 3:

This is the final step in achieving a high gloss finish. Remove any residue from the previous steps by using 3M's Finesse-it Finishing Material (#81235) with 3M's Super Buff Polishing Pad (yellow) at the lowest power setting. This step will remove any swirl marks that may have resulted from Step 2 and produce a high gloss finish. Reverse the yellow pad for final clean up.

2.12

Finishing Guidelines

STUDIO Collection® Color And Finishing Guidelines

STUDIO Collection® offers a wide range of unique products that are used in many different applications. Some of these products may not be suitable for high traffic applications due to their unique characteristics, dark hues, and saturated color.

Choosing the Right Finish

The design flexibility of solid surface offers us limitless options for style. With so many choices it makes it difficult to choose sometimes. One of the most confusing issues is the subject of finishing. Most manufacturers present 3 options commonly referred to as matte, satin, or gloss and ask the end user or designer to choose one of these. Quite often the contractor's quote assumes the least expensive matte finish as the default unless otherwise noted.

If the finish options are not discussed, most of the time customers are expecting to get the finish on the sample they are looking at when they choose the color. Managing the customer's expectations for finishing choices and overall performance is critical.

Choosing the right finish requires consideration of the color, texture, and application. Where it may be easier for a manufacturer or contractor to advise against a polished finish in a kitchen because of the concern for maintenance, it should not be the polished surface that causes concern but rather the color choice. Here is an example. Let's compare two color options both from the STUDIO Collection® Design Resin product line for an average kitchen countertop: Calacatta Stone (Left) and Midnight Sky (Right).



The light and neutral Calacatta Stone will not easily show signs of everyday wear but the Midnight Sky may show early signs of wear simply because of its color. This scenario would be true regardless of the finish chosen. A polished Calacatta Stone countertop can go years without showing any wear.

Finishing Dark Colors

This is a good time to discuss what finishes are appropriate for dark and rich colors like Midnight Sky. There are some of these colors in everyone's sample box. When it comes to extra dark colors like these, the "matte" finish is a very poor choice. Rough matte finishes on dark colors leave surfaces looking chalky and they easily smudge with fingerprints. All dark colors should have a minimum "satin" finish. Manufacturers put a minimum satin finish on the samples in their sample boxes because all of the colors look much better and cleaner.

Maintenance

Now let's consider the question of long term maintenance for different colors and finishes. Regardless of which finish was originally chosen, similar finishing steps must be applied to restore the surface to its original finish. There are two steps for a matte, three for a satin, and four steps for a high gloss. Because of the specialty equipment used to achieve a high gloss, end users wanting a polished finish must be prepared to acquire this equipment and technique or contract their installer to

refinish their surfaces periodically every 4 or 5 years depending on the application. In most cases, countertops that are used and cleaned everyday develop their own level of "patina". Matte surfaces become more reflective with use. It is generally agreed that the satin finish offers end users the best look with the minimum required maintenance. However maintaining a polished surface is only one more step than a satin finish. Overall hardness and scratch resistance of all solid surfaces are relatively the same. Anything that is harder than the surface has the potential to scratch. Items such as ceramic jars or stoneware for example should have felt protectors on the bottom to prevent scratching.

Texture

Texture refers to how much pattern you see in the color. Saturated colors with little texture will show wear easier than full textured colors. Compare these two colors illustrated below. These are two very popular black colors from the STUDIO Collection®. Notice the texture or pattern of the Black Ice versus very little pattern in the Midnight Sky. The extra texture in Black Ice will not show wear as easily as Midnight Sky or other saturated colors.

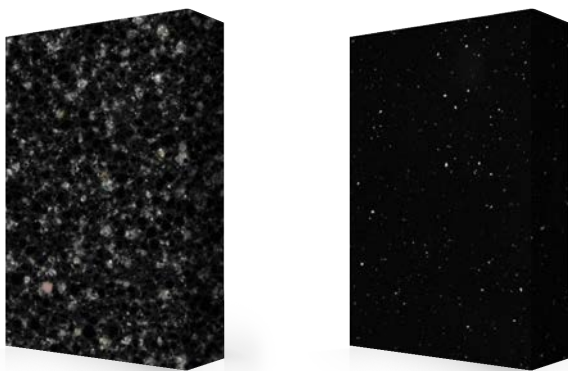

Special Exceptions

Some products in the STUDIO Collection® create a few exceptions to these general finish guidelines. Many of these products contain minimum levels of ATH filler. This allows the products to have a clear matrix that does not

show wear as easily as highly filled products. It is also this clear matrix that gives these products their depth and unparalleled beauty compared to all other products. This depth and clarity is enhanced by the polished finish. The combination of a clear matrix and a full texture like Black Ice create a very durable polished surface.

2.13

Designing and Fabricating with "Movement Colors"

The Movement Collection have characteristics that require some specific fabrication considerations. The random directional veining ranges from subtle to bold, so every sheet will be unique. The edge of the sheet can have a different appearance than the top of the sheet, and therefore should have consideration given to the desired edge effect. As a result of the random patterns in the sheets, sheet yields may be lower than standard patterns, therefore it is important to consider these characteristics when quoting jobs and setting the expectations of the customers. Larger samples and full sheet images help customers to visualize the final results.



Stacked Edges

Stacking edges reveals several layers and color differences through the thickness of the sheet. The variations are apparent and may cause objection from customers.



Drop Edge

The drop edge reveals one edge of the sheet thickness contrasted with the top surface. In some cases this contrast in pattern can be minimized with edge profiles such as an ogee or bevel.



V-Goove

Creating edges with a v-groove method produces an edge build that simply folds the top pattern over the side. The continuation of the top side pattern eliminates any pattern changes and is most preferred by customers.

Not all fabrication methods are suitable; those that work with subtle patterns may not work with bolder patterns. It is important to understand these characteristics and be able to set customer expectations.

3.1

Installation

It is very important that the personnel installing the STUDIO Collection® material be properly trained and follow the recommended procedures. Improper installation may lead to problems in the future. Failure to follow the recommended procedures will void the warranty.

Substrates

Choosing the appropriate substrate for different applications should be considered. A solid substrate cannot be used when heat sources are present, as in kitchen applications. The following methods demonstrate alternatives to solid substrates.

Runner Method

The runner method uses 1" x 4" (25.4mm x 101mm) supports that run parallel to the length of the top as shown in **Figure A**. They are at the front, center, and rear edge of the counter top, adhered with dabs of silicone every 18"-24" (45.7cm - 61cm). The cabinets must have cross supports for the runners every 18"- 24" (45.7cm - 61cm).

Clearances

Be sure to leave 1/16" (1.5mm) - 1/8" (3mm) between the edge of the substrate and the back of the build up. Leave a minimum 1/16" (1.5mm) between the counter top and the back wall. For wall to wall installations, allow clearance on each end for expansion. Leave a 1/8" (3mm) gap. Allow as much clearance as possible at cook tops and drop-in sinks.

Adhering Material to Substrates

Dabs of silicone are placed in the front, center, and rear every 18"- 24" (45.7cm -61cm) for all substrates. A dab of silicone should be the size of your thumb nail.

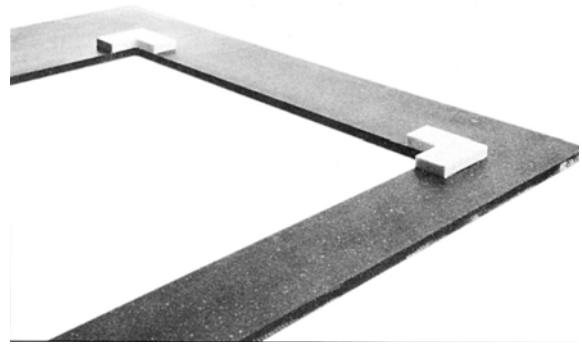

Corners of cook top cut outs must be reinforced by bonding a 3" (76mm) x 3" (76mm) or larger piece of STUDIO Collection® material to the underside. Do not position a joint or any glue lines across any type of cut out or hob. Always leave a 1/8 in. or 3 mm space between the underneath of an appliance and the edge of STUDIO Collection®.

Securing Top to Cabinets

We recommend attaching the substrate to the STUDIO Collection® top first and then fastening it to the cabinets. This way if you ever need to remove the top, you may do so without destroying it. Set tops on pre-leveled cabinets. Put screws from all corner blocks on cabinets into the substrate. Make sure screws do not go all the way through substrate and into the countertop. If screws are allowed to contact the solid surface, they may start a crack at that point. We recommend 100% silicone for bonding to wooden substrates. **NEVER USE LIQUID NAILS™** or other rigid adhesive which does not allow for expansion or contraction of the top.

ALL CUT OUTS SHOULD BE MADE WITH A TEMPLATE AND A ROUTER AND HAVE A MINIMUM 1/4" (6mm) INSIDE CORNER RADIUS.

Using the runner method substrate as pictured allows for venting of heat.

COOKTOP / HOB AND BACKSPLASH CLEARANCE

Due to excessive heat generated from cook tops and pans being heated, minimum clearances are required by Avonite Surfaces® material.

Standard 4" (102mm) tall splashes should have a minimum clearance of 2" (51mm) between the splash and the cook top flange.

Note to homeowner:

Full height splashes within 2-1/2" (63.5mm) from the cook top flange will not be covered under Avonite Surfaces® 15-Year Warranty. Extensive use of large oversized pans that overhang the counter should be avoided. Commercial type cook tops for residential use need to be supported inside cabinet base, so that cook top is not supported by countertop alone.

THERMO-FLOW TAPE

The use of STUDIO collection® Thermo-Flow tape is REQUIRED for prevention of damage in

cook top cut outs and slide-in ranges due to excessive heat. The use of any other tape voids the STUDIO Collection® 15-Year Warranty.

Thermo-Flow is a 2-1/2" (63.5mm) wide heat conductive aluminum tape with a glass backing that adds insulating properties. Install one layer of Thermo-Flow around the cut out as shown below.

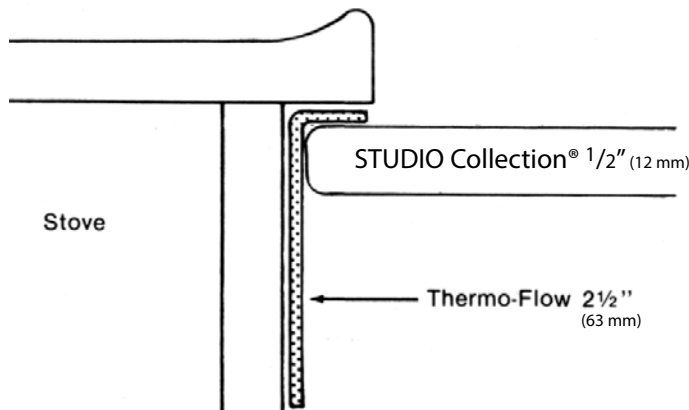

Commercial Food Service Hot Well Limitations Aristech Surfaces LLC does not warrant the use of STUDIO Collection® products for use in commercial hot well unit applications. This restriction will continue in effect until appropriate design criteria have been developed. We will keep you advised of any future developments in this area. Guidelines for installation of commercial hot wells are given on page 29.

Making Field Seams

To insure that drop edges are properly aligned after seaming, stop routing the profile a couple of inches from the seam on either side. After removing the flash line of the seam you may then route the profile across the seam.



INSTALLATION CHECKLIST

1. Before Seaming
 - a. Good dry fit (no gaps)
 - b. Seam block in place
 - c. Proper clearances
 - d. Clean with denatured alcohol
 - e. Prepared for clamping
2. Support all seams
3. Substrate secured to cabinets
4. Level cabinets 3/32" in 48" (2.38mm in 120cm)
5. Cutouts—1/4" (6.3mm) radius
6. Thermo-Flow tape on cook top cutout
7. Inside corner radius
8. Silicone

OVERHANGS

When installing overhanging countertops, support is required for 1/2" (12.7mm) thick overhangs extending more than 6" (152mm). Support is provided by plywood substrate or brackets which are equilateral right triangles (anchor leg is equal in length to the support leg). Backers can be MDF. Brackets, when required, are placed no more than 24" (60.9cm) apart and should come to within 5" (127mm) of the countertop edge. Refer to the dimensions below for the type of support to use.

OVERHANG SUPPORTS

Up to 6" (15.2cm) require no additional support.
 6" - 12" (15.2cm—30cm) require 3/4" (19mm) plywood substrate or brackets
 12" - 18" (30cm—45.7cm) require brackets or metal frame
 Overhangs more than 18" (45.7cm) should be engineered to no more than 1/8" (3mm) deflection.

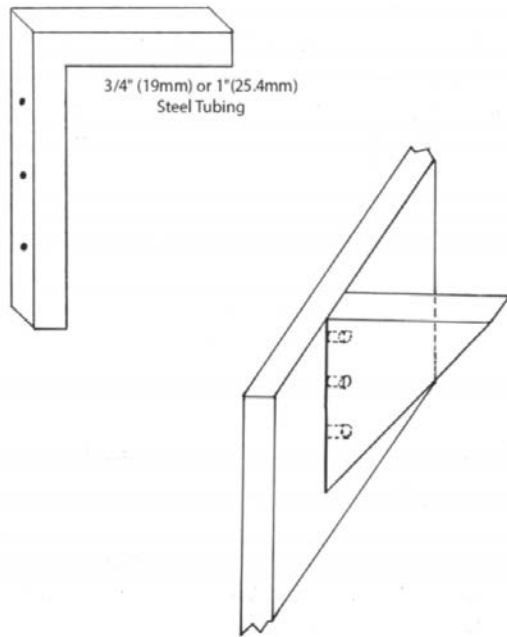
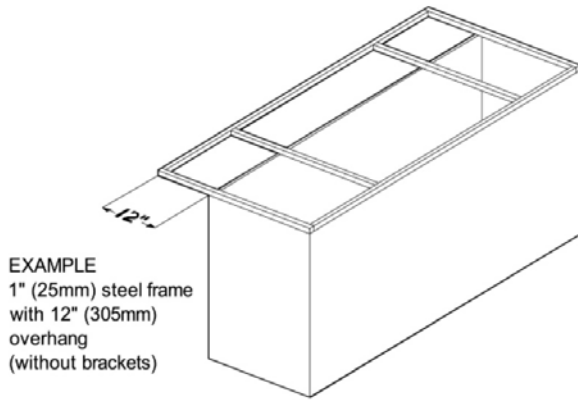

COMMERCIAL FOOD SERVICE AREAS

The following features must be included in a commercial food service installation in order to be covered by STUDIO collection® 15-Year Limited Warranty. Color must be selected from among STUDIO Collection® Class I fire rated products.

1. Cabinet must be even and level with no protrusions to cause cracking.
2. Support tops every 18" (45.7cm). Cantilevers over 6" (15.2cm) require structural support.

Provide support within 3" (7.6cm) of all cut outs.

3. Hot and cold units must be supported from below and not rest on the Avonite Surfaces® top.
4. Attach Avonite Surfaces® to support frame with dabs of silicone every 18" - 24" (45.7-61cm) ; do not use a continuous bead.

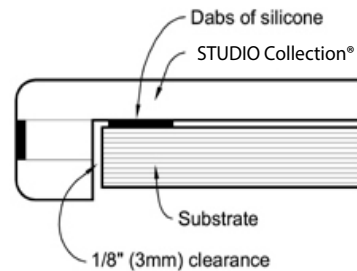

5. Separate tops containing hot sections from those with cold sections. A soft (silicone) seam may be used.

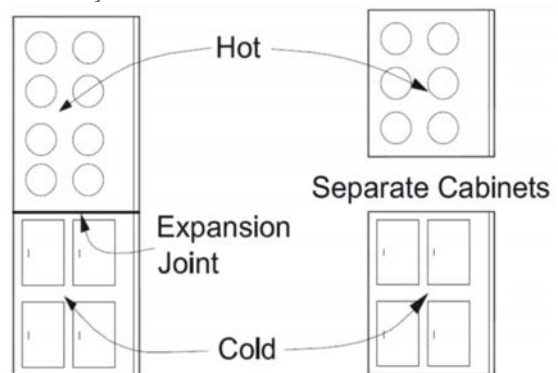

6. Make cut outs with router and template and allow a 1/2" (12.7mm) radius in the corners. Cut and sand a 1/8" (3mm) round over on top and bottom edge of cut out.
7. Reinforce corners of rectangular cut outs with 6" x 6" (15.2 x 15.2cm) blocks of STUDIO Collection®. Circular cut outs must have a continuous ring of STUDIO Collection® 2" (5cm) wide as reinforcement.
8. Use a layer of Thermo-Flow tape to line the perimeter of all hot and cold cut outs.

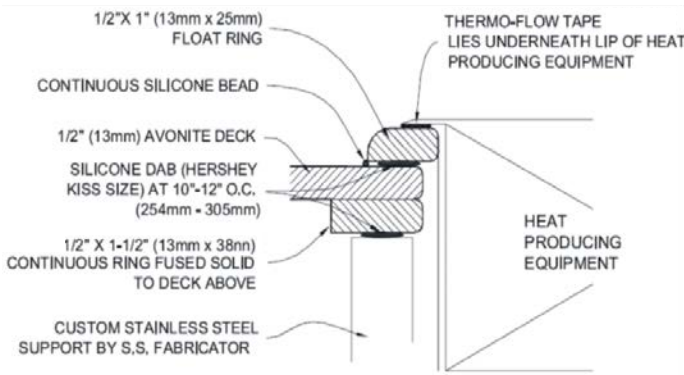

3.2 Sinks, Bases, Bowls

GENERAL SINK FUSED MOUNTING INSTRUCTIONS

Positioning and Preparation

Sinks are recommended for bonding to 1/2" (12 mm) STUDIO Collection® sheet thickness. Turn the sheet back-side up on a well supported surface. Position the bowl on the sheet.

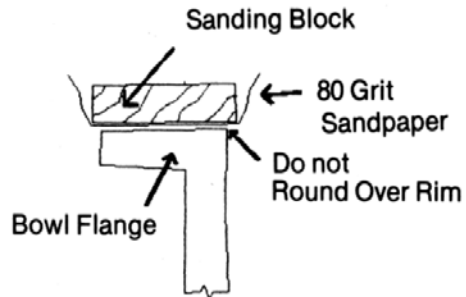
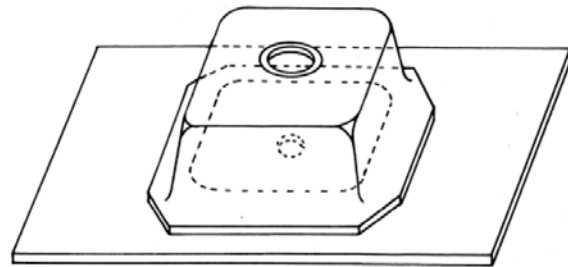

Do not nick or scuff the rim of the bowl. With a nail or screwdriver, etc., scratch a line on the sheet around the perimeter of the bowl. Drill a 1-1/4" (31.4mm) pilot hole, with a hole saw, in the sheet in line with the drain of the bowl. With a flat sanding block and #80 grit sandpaper, sand the underside of the sheet where the bowl is to be bonded. This removes factory sanding lines or scuff marks. With a flat sanding block, scuff sand with #80 grit sandpaper the top flange of the bowl. Do not round over or nick the rim. Mark the location of 4 locating blocks as shown below. These blocks can be scrap pieces of material 1" x 1-1/2" x 1/2" (25mm x 38mm x 12.7mm) thick. Fasten the blocks to the back of the sheet using Loctite 495, or equivalent. This will keep the sink from sliding during bonding.

9. Hot well units must be covered with a layer of Flex-Sulation blended PVC foam sheeting. The foam may be attached to the hot well with 3M® double sided aircraft tape, or duct tape.

McMaster Carr Supply 562-692-5911
Part # 9349K1

10. Cabinets are to be ventilated by installing a fan near the bottom to pull cool air into the cabinet and by providing vent slots near the upper edge of the cabinet to expel the hot air. Temperatures in the cabinet must not exceed 170°F (78°C).

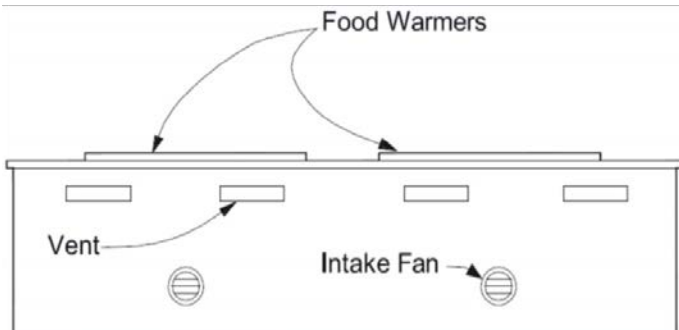

11. Sneeze guards must be fastened to the cabinets or the floor, not directly to the STUDIO Collection® sheet. Holes in the STUDIO Collection® sheet to accommodate the sneeze guard supports must be cut 1/4" (6mm) oversize in diameter to allow for expansion and contraction.

12. Deck seams must be reinforced with a 4" (10cm) seam block. Keep seams 3" (7.6cm) or more away from cutouts.

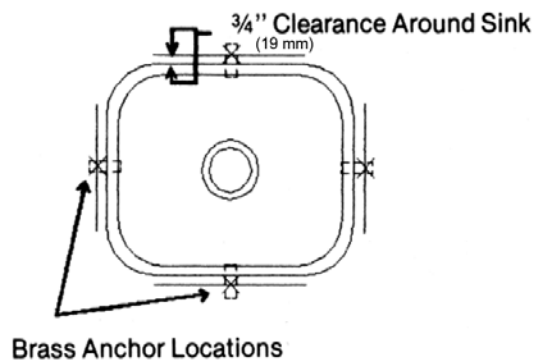

Bonding

Remove the bowl and clean the bonding area and the bowl with denatured alcohol and let it dry. Apply the adhesive to the sheet fully coating the flange area. Always use adhesive to match the bowl or sink. Use all-thread, two blocks of plywood and a wing nut to clamp the bowl to the sheet as shown below. Tighten the clamp until the adhesive flashes out evenly and allow the adhesive to harden. Refer to www.aristechsurfaces.com/studiocollection for adhesive color matches.

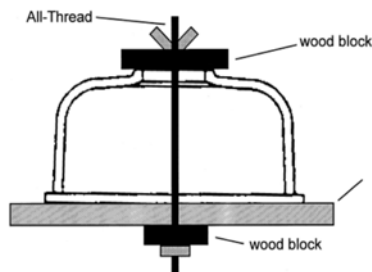

Mounting Brackets

Mounting brackets may be used to under mount sinks other than Avonite Surfaces® sinks. Drill a 1/4" (6mm) diameter hole by 1/2" (12mm) deep, 3/4" (19mm) from the sink into the locating blocks as shown in Figure 5. Remove any dust and tap in the brass anchors slotted end first. Set with Loctite. Mount hardware by first threading the wing nut well up on the screw near the head. With washer and slotted clip in place, tighten screw securely to lock the brass anchor (shown below). Bond the bowl to the sheet using silicone if it is a non-solid surface bowl. Swing clips on to the bowl lip and evenly tighten the wing nuts until the bracket begins to deflect. Recheck to be sure the bowl

is in the proper position. Allow the compound to harden. After adhesive cures, do not remove under mount brackets.

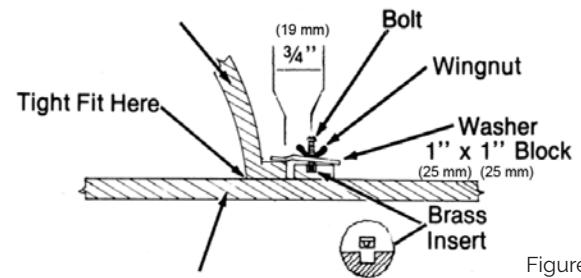

Figure 5

Shaping The Edge

Turn the top over and use the specially designed bowl router bits to shape either a flush or bull nose bowl edge trim. Cut the sheet material from the center of the bowl area with the special straight router bit with an over sized nylon bearing. Start from the pilot hole and rout clockwise around the bowl. Hold the cutout steady as it separates from the top to avoid damage to the edge (Figure 6). A bull nose trim on the edge (Figure 8 and 10) of the sheet creates a shadow which can help hide seams. The cutter slightly shaves the bowl edge and removes all the seam compound. A round over bit on the edge (Figure 7 and 9) of the sheet will produce a smooth edge. The cutter slightly shaves the bowl edge and removes all the adhesive. Different sheet thickness and cutter heights can produce various edge profiles.

NOTE: The bowl bits shown have a 2 1/2" (64mm) cutting diameter. Router base adjustments may be needed.

For additional information contact STUDIO Collection® Technical Services +1 (800) 428-6648.

NOTE: WHEN POURING BOILING WATER INTO THE SINK OR USING AN INSTANT HOT WATER DISPENSER, COLD WATER SHOULD BE RUNNING INTO THE SINK SIMULTANEOUSLY. THIS WILL ELIMINATE ANY POTENTIAL THERMAL SHOCK CRACK. THE USE OF A GARBAGE DISPOSAL LARGER THAN 3/4 HP IS NOT COVERED UNDER WARRANTY.

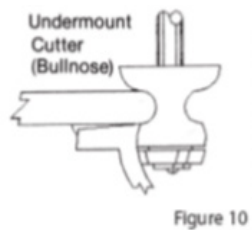
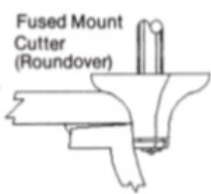
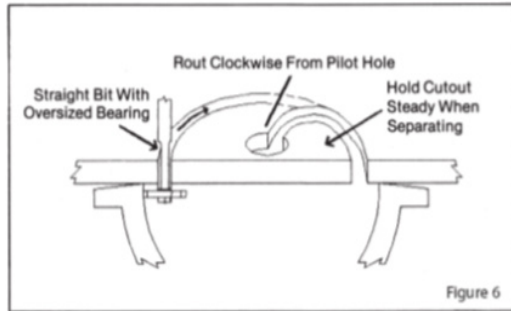

The bowl bit shown above is from Velepec
 # SUBN-8-12 4VT
 Velepec . 1-800-365-6636

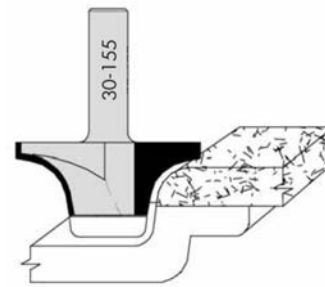

Kitchen Sink Rounding Over Bit—
 Velepec 30-155
 CRST10-8-8VTR
 1/2" (12mm) Radius for 1/2" (12mm) thick top

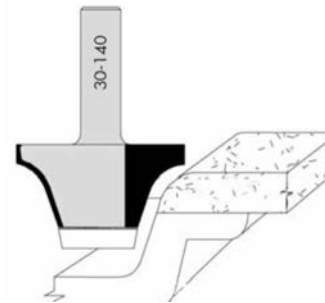

Vanity Sink Rounding Over Bit
 Velepec 30-157TG
 CRST 13-8-8VTR
 1/2" (12mm) Radius for 1/2" (12mm) thick top

4.1

Patching

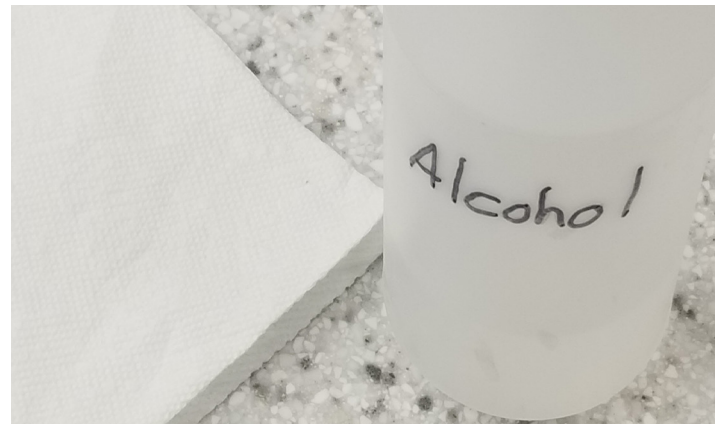

Mix particulate with patching resin in one large container. Stir mixtures thoroughly together.



PATCH KITS ARE AVAILABLE FOR STUDIO Collection®

PRODUCTS NEEDED FOR PATCHING:

- a. Patching Resin
- b. Catalyst (sold separately)
- c. Stirring Stick
- d. Particulate Can

Minimal damage — lightly rough out area to 3/16" (5mm) depth. You may need to rout out the area to hold patching material. Be sure to serrate edges of routed area to help blend in the patch.

Clean area with isopropyl alcohol. Allow to dry completely.

Compare color by placing a puddle of water next to the area to be patched. The amount of catalyst to be added should be measured by the amount of resin used not the total volume of both containers. (see section 4.3)



Patch material is difficult to bring to the same gloss as the sheet in a polished finish. A 100 watt light bulb to post heat the patch will help. Larger areas should be repaired with an insert of matching solid surface material.

Patch kits are not to be used to repair a bad or broken seam, (see Section 5.3) REPAIRS

4.2

Color Inlay

Products Needed For Inlay:

- Inlay Resin (same as Patching Resin)
- Colorant—Sign paint*
- Catalyst
- Stirring Stick
- Paper Cup

Route out slot for color inlay. It should be 1/8" (3mm) deep at a minimum. Contain over pour by placing masking tape or caulk around slot creating a damn about 1/8" (3mm) above the surface.

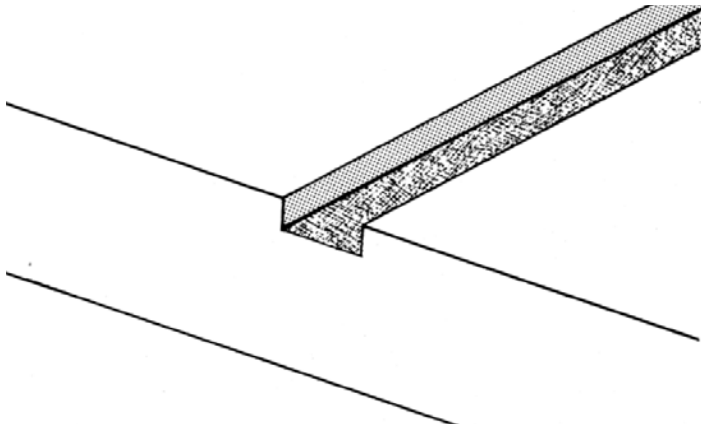

Add colorant to inlay resin, one drop per ounce. Add appropriate amount of catalyst and stir thoroughly. Pour mixture into prepared slot.

Over pour by 1/8" (3mm) to eliminate low spots and air bubbles.



Allow to dry thoroughly and finish. The hardening time is approximately 8 hours.

METAL INLAYS—Glue the metal to the bottom of the groove with Super Glue. It may then be over poured with clear resin. Over pour should be a minimum 3/32" (2mm) deep.

Fabricator Notes:

Inlay Resin is available in quarts. When making large inlays, color enough material to do the entire job. Custom colors will be difficult to match later.

Patch Kits are often used for decorative inlays. Particulate may also be special ordered in quart containers. Follow the same procedure above for inlay resin.

* Sign paint is a high pigment enamel paint such as Chromatic® or One Shot® usually found at art supply stores

4.3

Catalyst Ratio Chart

RATIO OF CATALYST DEPENDS ON TEMPERATURE

Ratio of Catalyst: Drops per one ounce of Patching/Inlay Resin.

EXAMPLE: Ten drops per one ounce of Patching/Inlay Resin.

Ambient temperature at 75° F (23.8° C).

Therefore: At an ambient temperature of 75° F (23.8° C) 4 ounces (113.4gm) of Patching/Inlay Resin would take 40 drops of catalyst.

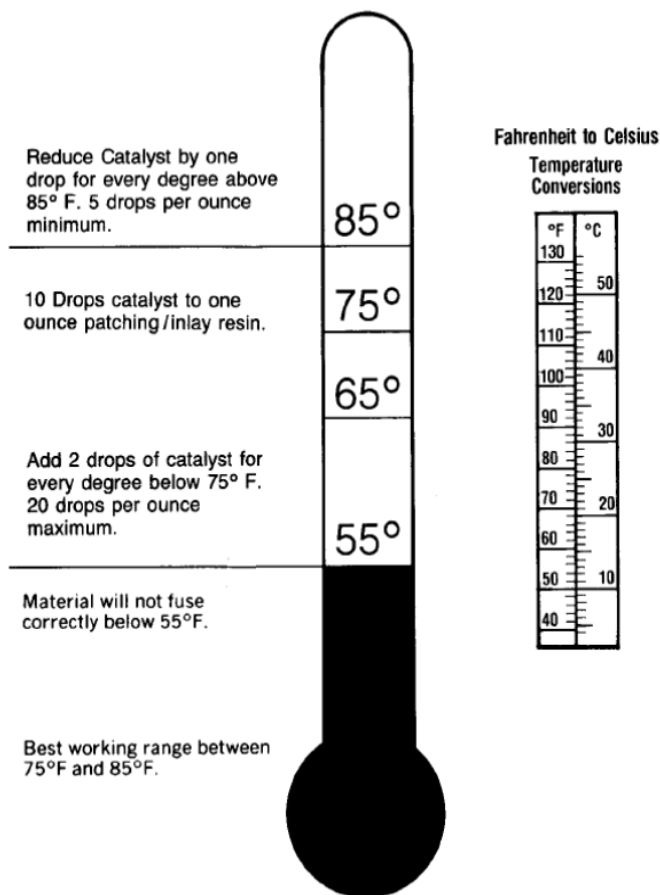

5.1

Wall Panels and Signage

INSTALLING SCREWS OR BOLTS IN STUDIO Collection® PANELS INTERIOR APPLICATIONS

Aristech Surfaces LLC realizes there are certain applications that need additional vertical support.

Examples: STUDIO Collection® outdoor signage, elevated wall cladding or ceilings etc., and other similar applications. The proper technique for installing screws or bolts through STUDIO Collection® sheets should be done according to the diagram below.

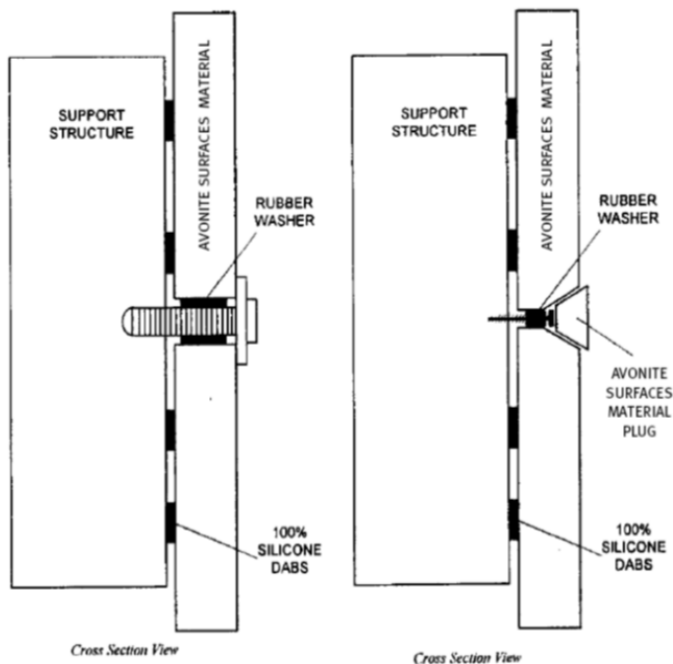

Soft seams should be used for exterior applications.

Important facts that you need to remember are:

1. Hole should be 1/4" (6mm) oversize in diameter minimum (for interior applications).
2. Hole should be 1/2" (12.7mm) oversize in diameter (for exterior applications).
3. Rubber grommet/washer needs to be

4. Do not over tighten screw or bolt; snug tight only.

Outdoor Applications

Aristech Surfaces LLC does not warrant exterior applications for the STUDIO Collection® product.

Engraving and Sandblasting

STUDIO Collection® material can be engraved by conventional carbide engravers and laser engravers. Letters or logos are easily cut out by computer controlled routers. STUDIO Collection® material can be sandblasted using a monument stencil like anchor Continental #111 or "Buttercut" by 3M. Silicon carbide (80 grit) at 80 psi gives the best results for a sharp edge.



5.2

Thermoforming

These Thermoforming Parameters are basic guidelines for fabricators to thermoform STUDIO Collection® material. The parameters listed below are recommendations, which are a direct result of actual forming of Avonite® material. This testing was conducted by the STUDIO Collection® Technical Service Department, but values are approximate. We suggest re-testing for varying conditions.

Material Preparation

When preparing material to be formed, it is recommended that material be cut to size. Then, remove all chips or gouges on the edge of the material. Any chip or gouge left on an edge may cause the material to tear during forming.

Thermoforming Temperature

Temperatures given here are approximate and represent a starting point to establish the conditions you need for your project. If material is too cool or too hot it may crack or tear while bending.

STUDIO Collection®

When heating material for forming, it is important to uniformly heat the entire thickness of the sheet. Spot heating or surface heating is not adequate to form the sheet stock. To achieve this, it is recommended that an oven designed for solid surface be used. Be aware that heating in an oven may darken the color of light colored material.

Oven Options

Below are thermoforming guidelines for conventional and platen style ovens. Every oven is unique and calibrations may be necessary. Be sure the oven used is large enough for the entire piece to be formed.

MOLD DESIGN

When forming we recommend that male and female molds be made. The molds need to be

designed so they can accommodate clamps to hold them together while material is cooling.

COOL DOWN

Allow material to cool for one hour, or when the temp reaches 100 F / 37 C, to prevent the material from springing back. If material is not allowed to cool adequately, it may spring back as much as 10% which will make any further fabrication of the application difficult.

FABRICATION: FINISHING/SEAMING

Finishing formed sheet stock is no different from standard finishing. However, it is important that any seaming/joining be done after forming. The heat to which the material is subjected will weaken the seamed areas of the pieces, which may result in seam failures.

Product Group	Conventional Oven			Platen Oven		
	Temperature	Time / Minutes	Minimum Radius "	Temperature	Time / Minutes	Minimum Radius "
STUDIO Collection® C III	254 F / 120 C	20 - 25	8" (203 mm)	212 F / 100 C	10 to 12	8" (203 mm)
STUDIO Collection® C I	270 F / 132 C	20 - 25	14" (355 mm)	225 F / 110 C	10 to 12	14" (355 mm)

5.3

Repairs

Most Common Reasons For Seam Failures

1. Excessive heat from belt sanding
2. Too much clamping pressure
3. Inadequate mixing of catalyst
4. Insufficient catalyst from cartridge if voids not purged by dispensing small quantity of Ultra Bond G before installing mixer tube
5. No seam block
6. Unsupported seams
7. Seams near heat source such as dishwasher or cook top
8. Seams placed at points of stress such as inside corners

Seam and Damage Repair

1. The damaged area must first be bonded back together. When the opening is wide enough, STUDIO Collection® Solid Surface Adhesive can be used. For tight cracks, a very thin cyano acrylate (Super Glue) could be used to fill the void.
2. After the glue has dried, route a groove about 1/4" (6mm) deep— See drawing
3. Glue a matching piece of STUDIO Collection® material into the groove. Always leave a piece of material on the job site for any future damage (perhaps on the floor beneath a bottom drawer or mounted in the sink cabinet).
4. Material may then be routed level and

sanded back to the original finish.

Pie Shape Repairs

The pie shape repair has proven to be one of the best methods of repairing cracks and damaged areas. The principal is to create a template large enough to encompass the damaged area. Clamp on the template and rout out the area to be replaced.

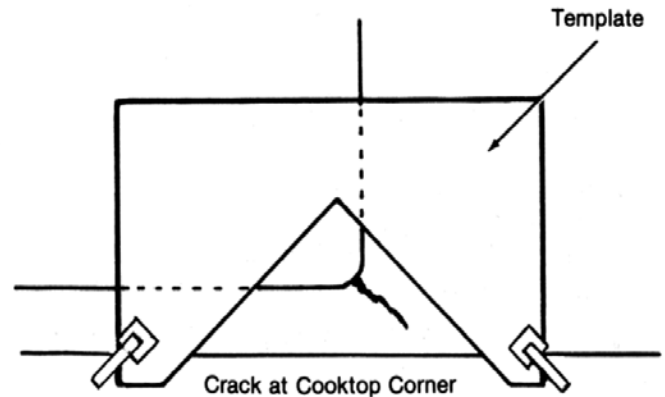

Cut a matching wedge piece to fit using the same template and router. Check the dry fit and adjust until there are no gaps. Glue the repair piece (s) in place with a reinforcing block underneath whenever possible.

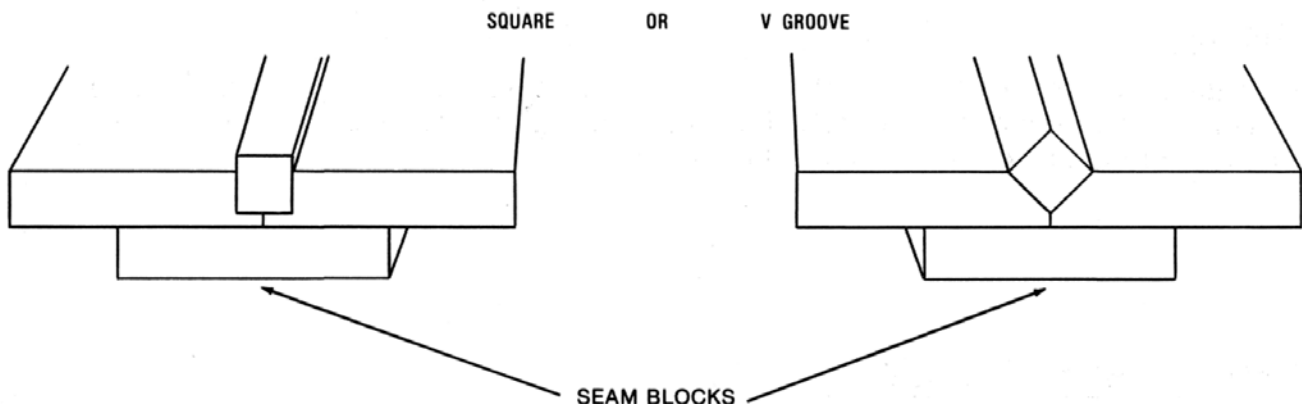
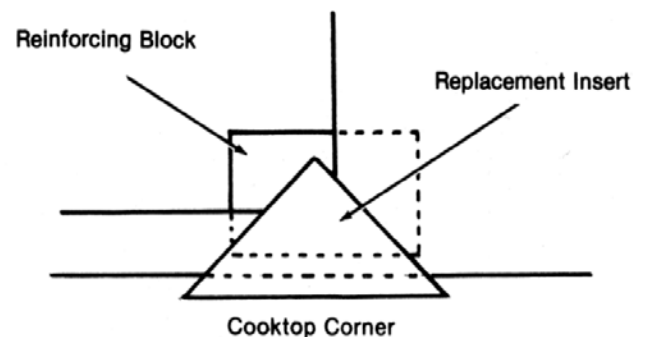

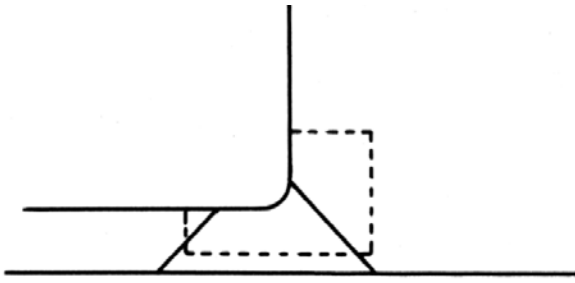

The methods and techniques have improved over the years and today there are several companies that offer repair templates and router bits that make repairs very quick and accurate.

Circle Template Repairs

The circle template repair is recommended for damages from heat producing appliances or hot pots that occur in the center of the counter. Templates By Andreas offers a selection of solid surface repair templates and tools. www.andreascustomdesign.com



Below is the 10 Degree Repair Kit available at www.specialtytools.com



5.4

Partitions

When choosing solid surface for partitions, allowances for expansion and contraction must be considered. Avoid rigid fasteners that will not move. Rubber or nylon sleeves should be used for bolts going through the partition.

Toilet Partitions

Choose only STUDIO Collection® Class I 12mm (1/2"). It is recommended that all hardware should have rubber or nylon grommets between the hardware and STUDIO Collection® Design Resin Surface.

1" (25mm) thick pilasters are recommended for support post running floor to ceiling.

For added strength, construct a 1" x 4" (25mm x 10cm) build-up with a 1/2" (12.7mm) channel for top and bottom rails.

Place no seams in stall doors.

Wall panels should be secured to back to walls with a full length "U" channel.

Partition hardware available at:

Bommer Industries Inc.
www.boomer.com
P.O. Box 187
Landrum, SC 29356
800-334-1654
864-457-3301

Jacknob Corp
www.jacknob.com
290 Oser Ave.
Hauppauge, NY 11788
631-231-9400

Decolam
www.decolam.com
2145, rue Lavoisier, suite 101
Quebec (Quebec)
Canada G1N 4B2
418-527-2544

6.1

Fabrication Support Materials

Aristech Surfaces LLC has created One-Stop Shopping convenience by making available all of the necessary fabrication products through your local distributor. If items listed below are not available from your distributor, please notify STUDIO Collection® Technical Services, +1 (800) 428-6648.

STUDIO Collection® Adhesive Cartridges

SM416**** or SM6***

*** Refers to 3 digit color code.

Refer to www.aristechsurfaces.com/studiocollection for complete list of color matched adhesives



Spare Mixing Tubes for 250ml size
SM4162-01

Dispensing Gun
SM4160-00 MANUAL



Inlay Resin—Quart

SM4130-00

Specially formulated inlay resin for creating custom detail designs in Avonite® material. Can be used with Avonite® Inlay Filler for an “intarsia” look.



Patch Kits

SM4021-**

Color coordinated Patch Kits each include (1) 4 oz.(113.4gm) can of filler, toners, and (1) 4 oz. (113.4gm) can of patching resin. Patch Kits are available in all current STUDIO Collection® colors. The catalyst hardener must be ordered separately (SM4001-10). This is MEKP-9 catalyst and is usually available locally.

Spring Clamps—2” or 3” (50.8 - 76.2mm)

SM4063-00

SM4063-01

Needed for equal and consistent pressure to avoid open joints. Standard equipment for every fabricator.



STUDIO Collection® Thermo-Flow Tape

SM4065-00

Insulates from excessive heat in cook top cut outs. One roll of tape contains 18 yards (16.45m).

6.2

Sanding and Polishing Accessories

Superbuff Polishing Pad (Yellow)

SM4046-00 Polishing Pad used with Finishing Material



Finesse-It Finishing Material

SM4058-00

Second step in polishing system (1 liter).



STUDIO Collection® Dry-Cut Finishing System

SM4036-A Brown bar

SM4036-B Blue stick

Polishing system

Step 1: Brown bar. SM4036-A

Step 2: Blue stick. SM4036-B



Superbuff 2 + 2 Pad (White)

SM4045-

Polishing Pad used with Marine Paste compound and STUDIO Collection® Dry-Cut Finishing System Compound.



6.3

Care and Maintenance

The final finish of STUDIO Collection® material should be specified in one of the following finishes: Matte, Satin, or High Gloss. Each customer must receive STUDIO Collection® Care & Maintenance information to ensure they understand the proper care and maintenance for the STUDIO Collection® installation and to register for the 15-Year Limited Warranty, or the new Installed Warranty as appropriate. The STUDIO Collection® Care & Maintenance information, as well as all warranty information is available online at www.aristechsurfaces.com.

MATTE FINISH

Cleaning:

Soap and water will clean most stains. For more stubborn stains use a green Scotch-Brite® pad and an abrasive cleanser.

Scratches:

To remove scratches, start sanding with 240 grit paper and then clean with an abrasive cleanser and a green Scotch-Brite® pad. Remember to periodically go over the entire matte surface with a dry, green Scotch Brite® pad to return the original finish.

SATIN FINISH

Cleaning:

Soap and water will clean most stains. For Stubborn Stains use a white Scotch-Brite® pad and non-abrasive cleanser such as Soft Scrub™.

Scratches:

To remove scratches, start sanding with 400 grit paper followed by 600 grit paper. Then clean the area with Soft Scrub™ and a white Scotch-Brite® pad.

HIGH GLOSS

Cleaning:

Soap and water will clean most stains. Use a polishing compound like 3M Perfect-It and a soft cloth to remove more stubborn stains.

Scratches:

To remove scratches from a high gloss finish, start sanding with 400 grit paper. The surface must then be machine polished back to its original finish. If you do not own or have access to this equipment, you should contact your local STUDIO collection® fabricator for assistance.

Avonite Surfaces® Sink Care

Use the Matte Finish cleaning and scratch removal procedures above. To keep sink color bright, clean occasionally with liquid bleach and water. Fill the sink 1/4 full with water, add 1 to 2 cups of bleach, wipe the sides of the sink and let stand for 15 minutes. Then drain the sink and rinse.

Do's and Don'ts Quick Reference

- Always use a hot pad or trivet under hot pots or heat producing appliances.
- Always use a cutting board.
- Never stand on your counters.
- Avoid harsh chemicals such as drain cleaners and paint removers.
- For high gloss counters, do place felt protectors on the bottom of pottery or other hard objects.
- Do avoid sliding hard objects across these glossy surfaces.
- Always run cold water when pouring boiling water into Avonite Surfaces® sinks.

6.4

Warranty Claims Processing

Warranty claims that are submitted with complete information will be resolved within two weeks of receipt of the claim. Without this information, the processing of a claim will be delayed. We ask for your continued cooperation and thank you for your assistance.

STUDIO Collection® TECHNICAL SERVICE DEPARTMENT +1 (800) 428-6648

FILING CLAIMS

To resolve warranty claims, we ask that our Distributor Representatives prepare a Warranty Claim Report. You can help us expedite the processing of warranty claims and achieve improved customer satisfaction by assisting in the following areas:

- 1. Warranty Claim Report Form** - Please fill form out completely so that the information needed to make decisions is readily available for us. This information helps us tremendously in the processing of the claim.
- 2. Quality Inspection Checklist** -We ask your assistance in completing this form in detail, as this helps us to identify how the defect occurred. Your help in this area in the past has led to the advanced fabrication procedures that now exist in the solid surface industry, further improving our industry's reputation.
- 3. Job Layout** -Include a detailed diagram of the job, complete with all measurements, including distances to seams and seam locations. This helps us to accurately estimate the cost of fabrication and material, thereby reducing errors and allowing us to validate a repair/replacement quote.
- 4. Photos** -Take three to four photographs (cell phone photos are acceptable) of the defective area and a photograph of the overall kitchen.
- 5. Quotation** -Submit a written quotation on the repair or replacement of the job. Repair is encouraged over replacement. However, if repair is not possible, a quote of the job replacement is needed.

6.5 Limited Warranty Interior

Limited Warranty Commercial and Residential Interior Applications

Aristech Surfaces LLC ("ARISTECH") warrants to the original purchaser of any of its manufactured solid surface products that ARISTECH will, at its option and sole discretion, repair or replace the product if such product fails due to an ARISTECH manufacturing defect which is discovered during the first fifteen (15) years after the initial purchase, subject to the limitations set forth in this Limited Warranty.

This Limited Warranty applies only to STUDIO Collection® products that have been fabricated and installed by an authorized ARISTECH fabricator who holds a certification dated four (4) years or newer at time of installation and has installed the product in accordance with the installation instructions provided by ARISTECH; which have been used as recommended; and which have failed due to a manufacturing defect and not from damage caused by physical abuse, structural movement, excessive heat, or breakage not due to a defect in the manufacture of the solid surface. This Limited Warranty does not cover defects or damage caused by or resulting from failure of any adhesive, caulk or other accessory, or failure of any caulked or filled joint or seam. This Limited Warranty covers the product for normal interior use, but does not cover the product if it has been moved from its original place of installation. Labor charges incurred during installation are not included under this Limited Warranty. This is a product only Limited Warranty, not a fabrication or installation warranty.

Some variance in color or pattern is natural and can occur. Exact matching of color or color of replacement product is not guaranteed.

This Limited Warranty applies to STUDIO Collection® products that are purchased after June 1, 2018, and maintained as described by the STUDIO Collection® care and maintenance guide. (The care and maintenance guide may be found on the website at www.aristechsurfaces.com.) For coverage under this warranty, you must register online at www.aristechsurfaces.com. The Company will assign a warranty registration number.

This warranty may be transferred or assigned. If transferred or assigned, the subsequent owner must submit a new warranty registration form to ARISTECH within 30 days of the transfer or assignment from the original purchaser or current warranty holder. Once registered, this Limited Warranty will remain in effect for the duration of the original warranty term. Failure to register within 30-days of original purchase, transfer or assignment, will void the warranty.

To obtain service under this warranty, write to the dealer/contractor from whom you purchased the product or alternatively write to Aristech Surfaces LLC at the address below providing your name and address, warranty registration number, a description of the product involved, and the nature of the defect or failure. Repair or replacement shall not include any labor charges. A warranty registration number, purchase receipt or other acceptable proof of purchase will be required before any warranty claim can be considered.

Exclusive jurisdiction for legal disputes relating to alleged breach of warranty or representation of any nature must be filed in either the state or federal courts located in Boone County, Kentucky. Kentucky law will govern all disputes or claims arising out of the sale, purchase or use of the solid surface products.

The address to which Warranty claims should be reported is:

Aristech Surfaces LLC
Attn. Director of Quality
7350 Empire Drive
Florence, KY 41042

ARISTECH may ship (freight collect) to you products repaired or replaced under this Limited Warranty.

THIS LIMITED WARRANTY IS IN LIEU OF ALL OTHER WARRANTIES, AND ARISTECH EXPRESSLY DISCLAIMS ALL OTHER WARRANTIES, EXPRESS OR IMPLIED, INCLUDING WITHOUT LIMITATION ANY IMPLIED WARRANTY OF MERCHANTABILITY, FITNESS FOR A PARTICULAR PURPOSE (EVEN IF THE PURPOSE IS KNOWN TO ARISTECH), OR FROM COURSE OF DEALING OR TRADE USAGE. THIS LIMITED WARRANTY SETS FORTH THE SOLE REMEDY IN CONNECTION WITH THE SALE OR USE OF PRODUCTS COVERED BY THIS LIMITED WARRANTY AND IN NO EVENT SHALL ARISTECH BE OTHERWISE LIABLE FOR ANY LOSS, DAMAGE OR INJURY OF ANY NATURE ARISING OUT OF THE SALE OR USE OF THE PRODUCTS DELIVERED HEREUNDER, WHETHER FOR NEGLIGENCE, BREACH OF CONTRACT OR UNDER ANY OTHER LEGAL OR EQUITABLE THEORY. ARISTECH SHALL NOT BE LIABLE FOR ANY INDIRECT, SPECIAL OR CONSEQUENTIAL DAMAGES ARISING OUT OF THE SALE OR USE OF SUCH PRODUCTS, INCLUDING BUT NOT LIMITED TO LOST PROFITS, REVENUES, ANTICIPATED SALES, BUSINESS OPPORTUNITIES OR FOR INTERRUPTION OF BUSINESS.. ARISTECH ASSUMES NO LIABILITY FOR IMPROPER FABRICATION, INSTALLATION AND/OR THE USE OF ADHESIVES NOT MANUFACTURED OR DISTRIBUTED BY ARISTECH.

*Some states do not allow the exclusion or limitation of incidental or consequential damages, so the above limitation or exclusion may not apply to you. This warranty gives you specific legal rights, and you may also have other rights which may vary from state to state.

Note: This Limited Warranty does not include items identified as 'wear items' that can be purchased through Aristech Surfaces. If you require replacement of a 'wear item', please contact ARISTECH.

Effective June 1 , 2018

IMPORTANT NOTICE

The information and statements herein are believed to be reliable but are not to be construed as a warranty or representation for which we assume legal responsibility. User should undertake sufficient verification and testing to determine the suitability for their own particular purpose of any information or products referred to herein. **NO WARRANTY OF FITNESS FOR A PARTICULAR PURPOSE IS MADE.** Nothing herein is to be taken as permission, inducement or recommendation to practice any patented invention without a license. Any information or suggestion concerning applications, specifications or compliance with codes and standards is provided solely for your convenient reference and without any representation as to accuracy or suitability. Aristech Surfaces LLC disclaims any responsibility. The user must verify and test the suitability of any information or products for his specific application.

STUDIO
COLLECTION®

A BRAND OF ARISTECH SURFACES LLC

www.aristechsurfaces.com/studiocollection

+1.800.354.9858 | info@aristechsurfaces.com

GLOBAL HEADQUARTERS | 7350 Empire Drive, Florence, KY 41042, USA | +1.800.354.9858

INTERNATIONAL OFFICES | Unit 301, Clerkenwell Workshops, 27/31 Clerkenwell Close, Farringdon, London ECR 0AT | UK | +44.208.065.5405